

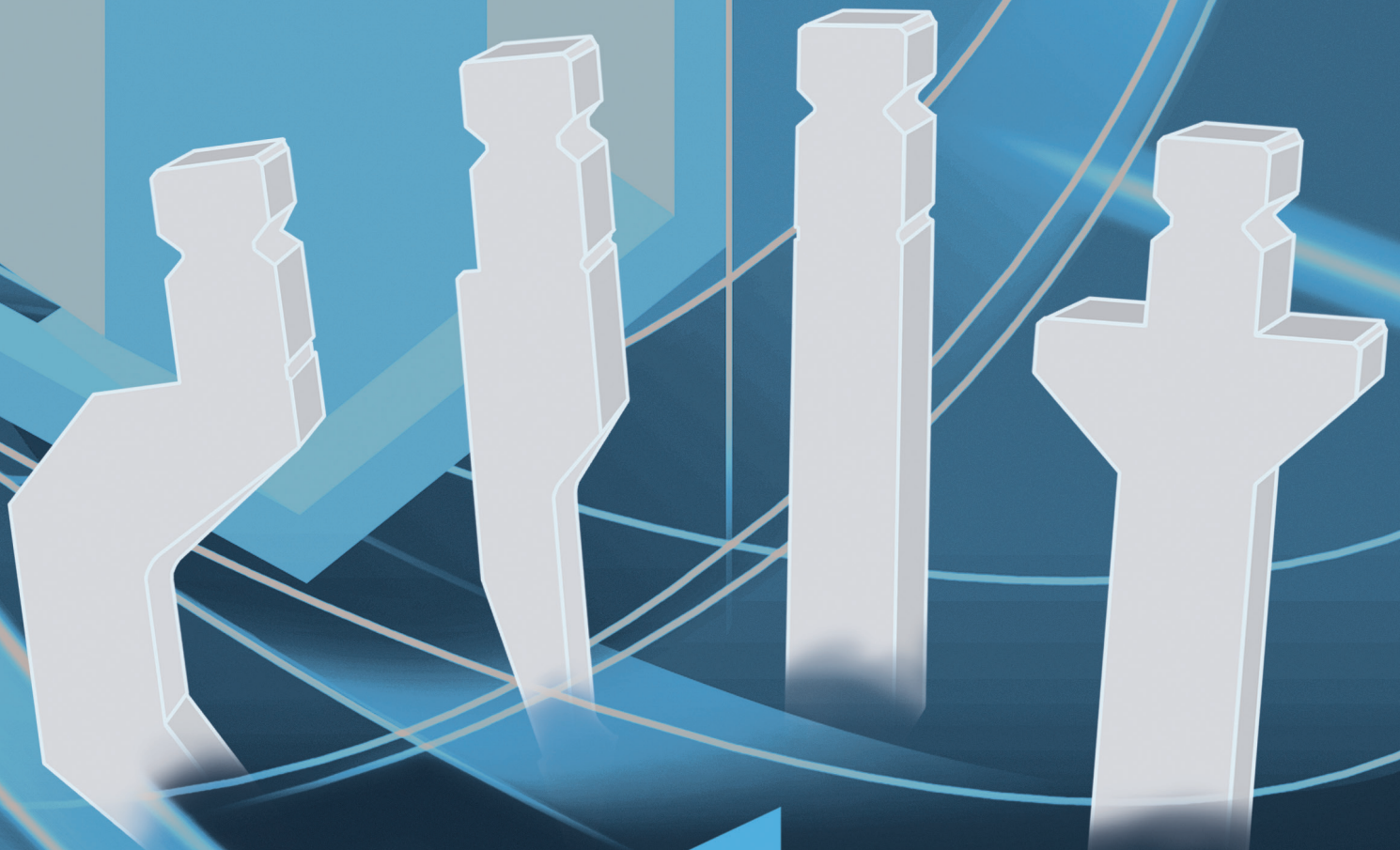

Toolspress

high quality tooling systems



tools  press

TRUMPF STYLE
Press Brake Tooling

www.toolspress.com

VERSION 1.1

tools press

Spirito d'Innovazione

Toolspress è leader mondiale nella progettazione e produzione di utensili e sistemi di bloccaggio di alta qualità, per presse piegatrici. Realizziamo prodotti all'avanguardia ed innovativi, sfruttando 30 anni di esperienza ed un ampio programma di produzione, con più di mille modelli standard, che ci permettono di valutare e risolvere le problematiche proposteci, ottimizzando i vostri sistemi di piegatura.

Toolspress è composta da Quattro importanti divisioni:

- Utensili Standard di Alta Precisione per Presse Piegatrici
- Utensili Speciali di Alta Precisione per Presse Piegatrici
 - Sistemi di Bloccaggio per Presse Piegatrici
 - Soluzioni Industriali per Presse Piegatrici
 - Lame da cesoia

Queste quattro divisioni sono indipendenti e utilizzano le tecnologie più avanzate disponibili nel mercato mondiale, in questo modo possiamo garantire prodotti di alta qualità senza paragoni. La qualità Toolspress è ben conosciuta nel mercato mondiale da molti anni. I nostri clienti sono per noi partners tecnologici, grazie ad una stretta collaborazione, risolviamo e incrementiamo le loro performance di piegatura. Il mercato globale richiede sempre più tecnologia a prezzi molto competitivi e nel minor tempo possibile, per questi motivi la nostra società ricerca e sviluppa metodi di produzione che ci permettono di soddisfare le richieste dei nostri clienti.

The Spirit of Innovation

Toolspress is a world-class designer and manufacturer of high-quality press brake tooling and clamping system. We provide the most innovative products in the fabricators industries. Through a great manufacturing program with more than thousand standard model, we are able to guide your choice of the best bending system in the fastest time, due to the long experience we got in 30th years.

Toolspress has four important divisions:

- Precision Ground Standard Press Brakes Tooling
- Precision Ground Special Press Brakes Tooling
 - Press Brakes Clamping System
 - Industrial Solutions for Press Brakes
 - Shear blades

These four divisions are independent and both use the ultimate technologies in manufacturing process available in the world market, in this way we can guarantee high precision quality products with no comparison. Toolspress quality is very well known in the world market since many years. Ours customers are for us technological partners, in fact through a tight cooperation they let us solve and improve their bending performance. The global market needs always more and more technology to a very competitive prices in the shortest time. In this way our company develops manufacturing methods that allow us to meet our costumers requirements.

The Spirit of Innovation

Toolspress® ist der weltweit führende Entwickler und Hersteller von qualitativ hochwertigen Abkantwerkzeugen und Werkzeug-Spannsysteme. Wir entwickeln und vertreiben die innovativsten Produkte im Bereich der Abkanttechnik. Durch unser großes Herstellungsprogramm mit über tausend Standardwerkzeugen sind wir in der Lage, das von Ihnen gewünschten Werkzeugsystem innerhalb kürzester Zeit zu liefern. Toolspress® verfügt über eine 30-jährige Erfahrung in der Abkanttechnik.

Toolspress® hat vier wichtige Bereiche:

- Präzisions Standard Abkantwerkzeuge
- Präzisions Spezial Abkantwerkzeuge
- Spannsysteme für Abkantwerkzeuge
- Industrielle Lösungen für Abkantpressen
 - Shear blades

Diese vier Bereiche sind unabhängig, aber alle nutzen die neuesten auf dem Weltmarkt verfügbaren Fertigungstechnologie. Auf diese Weise können wir hochpräzise Qualitätsprodukte ohne Kompromisse garantieren.

Die Qualität von Toolspress® ist seit Jahren auf dem Markt bekannt.

Für uns sind unsere Kunden technologische Partner.

In enger Zusammenarbeit werden Lösungen erreicht und Abkantleistungen verbessert. Die globalen Marktanforderungen fordern immer mehr Technologien, zu wettbewerbsfähigen Preisen, in kürzester Zeit. Daher entwickeln wir ständig neue Herstellungsverfahren, die es uns erlauben den Kundenanforderungen zu entsprechen.

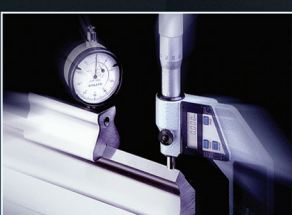

Terms and Conditions

Order	Minimum order is 100 €
Credit	All orders are subject to the approval of our credit department. If you are a new account, please furnish us with a bank reference and three supplier references. A credit limit will be imposed on new accounts until credit has been established.
Payment	Terms are net 30 days.
Cancellation	In the event an order is cancelled, a charge will be made to cover labour, materials and overheads.
Returned Material	A handling charge of 25% is made on all standard parts returned for credit. Written permission and shipping instructions must be obtained before the return of any material. Special tooling cannot be returned.
Claims	All claims for shortages must be made within 3 days of the invoice date.
Prices	Prices and specifications subject to change without prior notice. E & O E. All prices are exclusive of VAT.
Delivery Charge	All orders are subject to a delivery charge. Please call the sales desk for a delivery quotation.

Termini e Condizioni

Ordini	Importo minimo 100 €
Offerta contrattuale	Le ordinazioni che pervengono alla nostra società si intendono accettate solo se confermate per iscritto. La Tp Tooling si riserva il diritto di rifiutare la proposta e/o l'ordinazione qualora la società acquirente non fornisca prova adeguata della propria identità e/o ragione sociale, sia stato inadempiente nei nostri confronti, risulti iscritto nell'elenco dei protesti o soggetto a procedure esecutive o giudiziarie.
Pagamento	Salvo contraria pattuizione da concordare ordine per ordine, il pagamento dovrà essere effettuato con R.B. a 30 gg D.F.F.M. I pagamenti devono inoltre essere effettuati nei termini e con le modalità precisati nella conferma d'ordine.
Cancellazione ordine	In caso di cancellazione dell'ordine saranno addebitati i costi di produzione sostenuti.
Resi	I resi dovranno essere autorizzati dalla Tp Tooling prima di essere spediti. Gli utensili standard potranno essere resi addebitando comunque all'Acquirente un importo pari al 25% del valore della stessa fornitura. Gli utensili speciali non potranno essere resi.
Reclami	Eventuali reclami dovranno essere resi noti per iscritto alla Tp Tooling entro e non oltre 8 giorni dal ricevimento della merce.
Prezzi	Il prezzo è quello in vigore al momento della sottoscrizione della conferma d'ordine, fatta eccezione per eventuali aumenti imposti dal mercato.
Consegna	Il prezzo si intende per resa franco stabilimento Tp Tooling



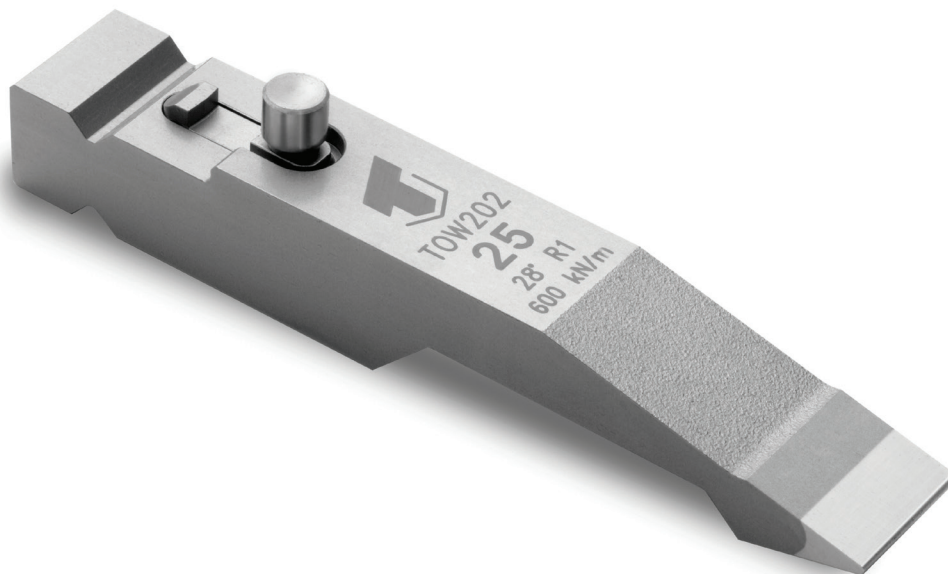

Safety clicks standard on all punches below 12,7 kg

Description	Description	Description
Punch Button Assembly - 10mm	Punch Button Assembly - 24mm	Punch Button Assembly - 30mm

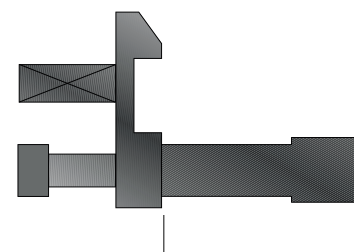
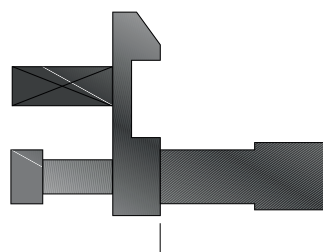
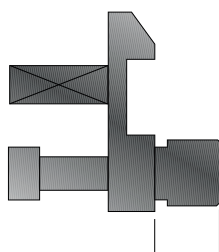

Description
Punch Button Assembly - 35mm

Description
Punch Button Assembly - 45mm

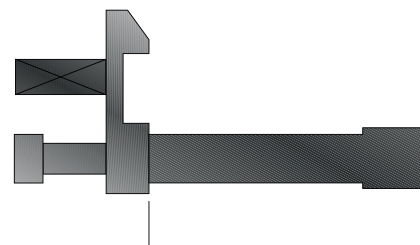
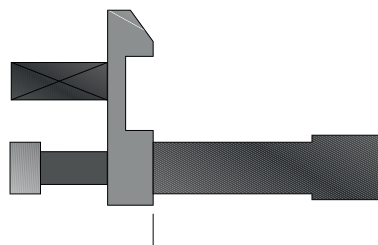

System division - Punches

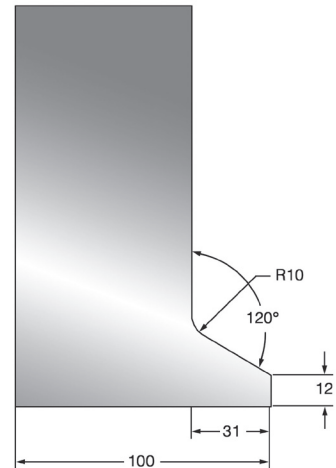
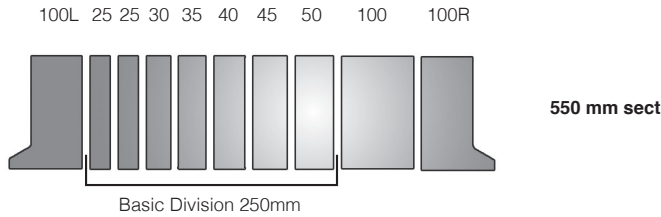
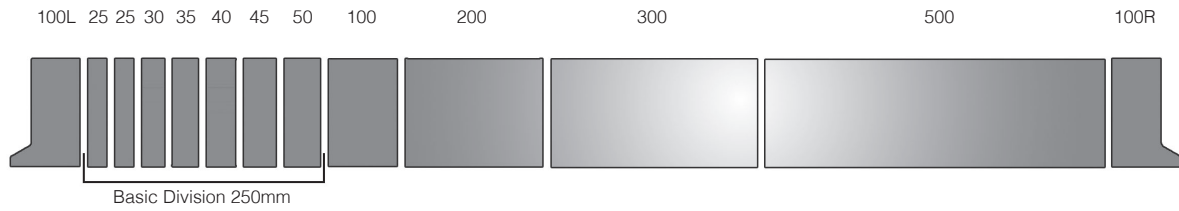

Version B

Set	100L	250X	100	200	300	500	100R
1050	1	1	1	1	1	0	1
1250	1	1	1	2	1	0	1
2050	1	1	1	1	1	2	1
2550	1	1	1	1	1	3	1
3050	1	1	1	1	1	4	1
4050	1	1	1	1	1	6	1

Division version for tool sets with a weight of up to 50kg/m

Set	100L	250X	100	200	300	500	100R
1050	1	1	1	1	1	0	1
1250	1	1	1	2	1	0	1
2050	1	1	1	3	3	0	1
2550	1	1	1	4	4	0	1
3050	1	1	1	5	5	0	1
4050	1	1	1	7	7	0	1

Division version for tool sets with a weight of more than 50kg/m

Version A

Set	100L	250X	100	100R
1050A	1	1	6	1
1250A	1	1	8	1
2050A	1	1	16	1

Benefit version B

- High flexibility
- Fewer tool change-overs
- Short tool set-up time
- Version most often selected and recommended
- Low purchase cost

Benefit version A

- Maximum flexibility
- Weight of the individual part pieces very low
- Maximum tool set-up time
- All tools can be loaded vertically and horizontally

SYSTEM DIVISION VERSION B/A

The combination of a punch block A-division and a die block in B-division will not cause any problems

Punches - Swan Neck

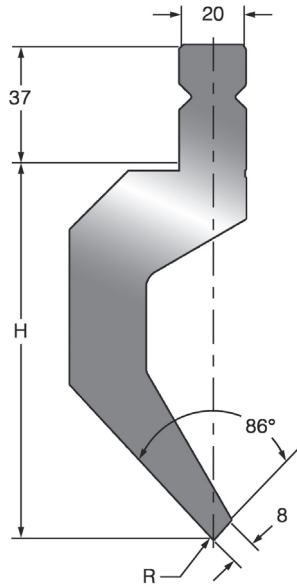

Toolspress Profile	TOW200
Trumpf Profile	OW200/K
Radius	R1
Angle	86°
Height	120
Maximum Loading:	800 kN/m
Weight:	29.1 kg/m

Version B	Sectionalised
Description	Description
Length 4050	250
Length 3050	550
Length 2550	Single
Length 2050	Description
Length 1250	500
Length 1050	300
Version A	200
Description	Horn right
Length 2050	Horn Left
Length 1250	100
Length 1050	50
	45
	40
	35
	30
	25

Dimensions in mm

Modified Punch Tip Radii									
R0.5	R1.6	R2	R2.3	R2.5	R3	R3.2	R4		Radius
86°	86°	86°	86°	86°	86°	86°	86°		Angle
119.8	119.2	119.2	119	119	118.7	118.6	118.3		Height

Punches - Thin Tip

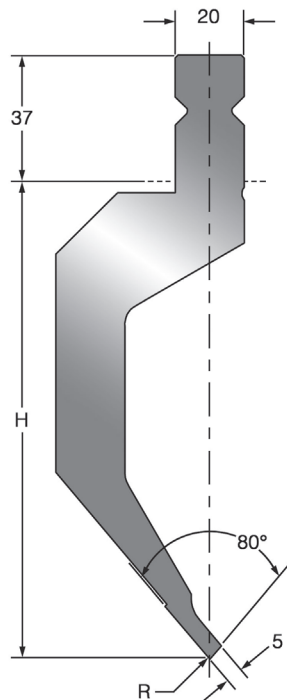

Toolspress Profile	TOW280
Trumpf Profile	OW280/K
Radius	R0.5
Angle	80°
Height	140
Maximum Loading:	400 kN/m
Weight:	30.9 kg/m

Version B	Sectionalised
Description	Description
Length 4050	250
Length 3050	550
Length 2550	Single
Length 2050	Description
Length 1250	500
Length 1050	300
Version A	200
Description	Horn right
Length 2050	Horn Left
Length 1250	100
Length 1050	50
	45
	40
	35
	30
	25

Punches - Goose Neck

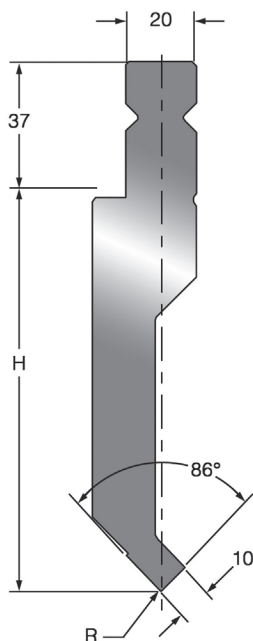

Toolspress Profile	TOW201
Trumpf Profile	OW201/K
Radius	R1
Angle	86°
Height	120
Maximum Loading:	800 kN/m
Weight:	24.3 kg/m

Version B	Sectionalised
Description	Description
Length 4050	250
Length 3050	550
Length 2550	
Length 2050	Single
Length 1250	Description
Length 1050	500
	300
	200
Version A	Horn right
Description	Horn Left
Length 2050	100
Length 1250	50
Length 1050	45
	40
	35
	30
	25

Dimensions in mm

Modified Punch Tip Radii									
R0.5	R1.6	R2	R2.3	R2.5	R3	R3.2	R4	Radius	
86°	86°	86°	86°	86°	86°	86°	86°	Angle	
119.8	119.4	119.2	119	119	118.8	118.6	118.2	Height	

Punches - Pointed with Recess

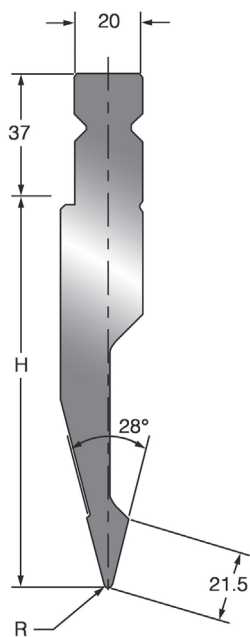

Toolspress Profile	TOW202
Trumpf Profile	OW202/K
Radius	R1
Angle	28°
Height	120
Max. Loading (Bending):	600 kN/m
Max. Loading (Flattening):	800 kN/m
Weight:	19.5 kg/m

Version B	Sectionalised
Description	Description
Length 4050	250
Length 3050	550
Length 2550	
Length 2050	Single
Length 1250	Description
Length 1050	500
	300
	200
Version A	Horn right
Description	Horn Left
Length 2050	100
Length 1250	50
Length 1050	45
	40
	35
	30
	25

Dimensions in mm

Modified Punch Tip Radii									
R0.5	R1.6	R2	R2.3	R2.5	R3	R3.2	R4	Radius	
28°	28°	28°	28°	28°	28°	28°	28°	Angle	
119.8	117.2	116	115.1	114.4	112.8	112.7	109.8	Height	

Punches - Pointed/Bottoming

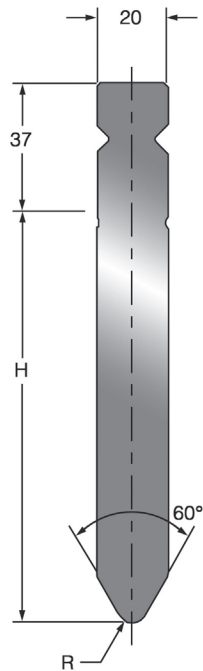

Toolspress Profile	TOW203
Trumpf Profile	OW203/K
Radius	R4
Angle	60°
Height	120
Maximum Loading:	1800 kN/m
Weight:	23.3 kg/m

Version B	Sectionalised
Description	Description
Length 4050	250
Length 3050	550
Length 2550	Single
Length 2050	Description
Length 1250	500
Length 1050	300
Version A	200
Description	Horn right
Length 2050	Horn Left
Length 1250	100
Length 1050	50
	45
	40
	35
	30
	25

Dimensions in mm

Modified Punch Tip Radii							
R2	R2.5	R3	R4.7	R5	R6	R6.35	Radius
60°	60°	60°	60°	60°	60°	60°	Angle
119.8	119.8	119.8	119.1	118.8	117.6	117.2	Height

Punches - Pointed with Flattened Spot

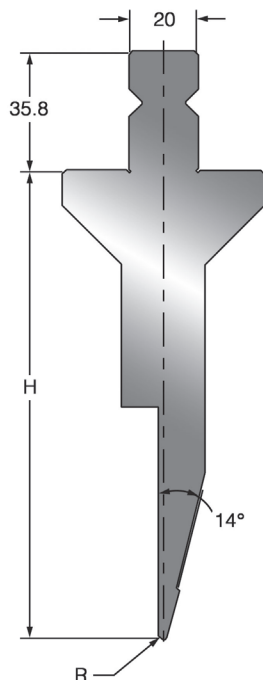

Toolspress Profile	TOW210
Trumpf Profile	OW210
Radius	R1
Angle	28°
Height	140
Max. Loading (Bending):	400 kN/m
Max. Loading (Flattening):	1300 kN/m
Weight:	28.9 kg/m

Version B	Sectionalised
Description	Description
Length 4050	250
Length 3050	550
Length 2550	Single
Length 2050	Description
Length 1250	500
Length 1050	300
Version A	200
Description	Horn right
Length 2050	Horn Left
Length 1250	100
Length 1050	50
	45
	40
	35
	30
	25

Dimensions in mm

Modified Punch Tip Radii	
R0.5	Radius
28°	Angle
139.8	Height

Punches - Swan Neck

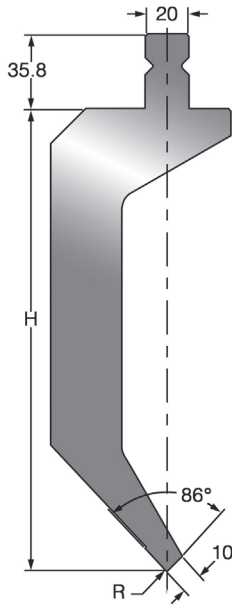

Toolspress Profile	TOW200S
Trumpf Profile	OW200/S
Radius	R1
Angle	86°
Height	220
Maximum Loading:	800 kN/m
Weight:	66,3 kg/m

Version B	Sectionalised
Description	Description
Length 4050	250
Length 3050	550
Length 2550	Single
Length 2050	Description
Length 1250	300
Length 1050	200
Version A	Horn right
Description	Horn Left
Length 2050	100
Length 1250	50
Length 1050	45
	40
	35
	30
	25

Dimensions in mm

Modified Punch Tip Radii									
R0.5	R1.6	R2	R2.3	R2.5	R3	R3.2	R4	R6	Radius
86°	86°	86°	86°	86°	86°	86°	86°	86°	Angle
219.8	219.2	219.2	219	218.7	218.5	218.5	218.3	217.5	Height

Punches - Goose Neck

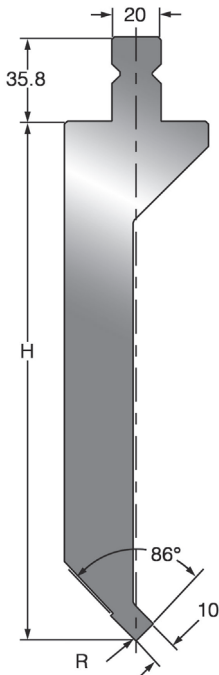

Toolspress Profile	TOW201S
Trumpf Profile	OW201/S
Radius	R1
Angle	86°
Height	220
Maximum Loading:	800 kN/m
Weight:	57.0 kg/m

Version B	Sectionalised
Description	Description
Length 4050	250
Length 3050	550
Length 2550	Single
Length 2050	Description
Length 1250	300
Length 1050	200
Version A	Horn right
Description	Horn Left
Length 2050	100
Length 1250	50
Length 1050	45
	40
	35
	30
	25

Dimensions in mm

Modified Punch Tip Radii									
R0.5	R1.6	R2	R2.3	R2.5	R3	R3.2	R4	Radius	
86°	86°	86°	86°	86°	86°	86°	86°	86°	Angle
219.8	219.4	219.2	219	218.7	218.8	218.6	218.3	Height	

Punches - Pointed with Recess

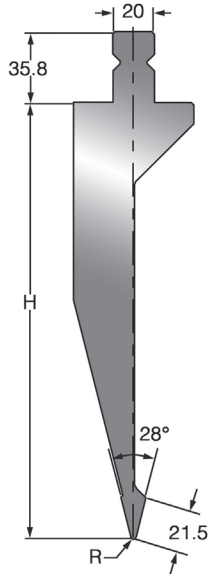

Toolspress Profile	TOW202S
Trumpf Profile	OW202/S
Radius	R1
Angle	28°
Height	220
Max. Loading (Bending):	600 kN/m
Max. Loading (Flattening):	800 kN/m
Weight:	49.6 kg/m

Version B	Sectionalised
Description	Description
Length 4050	250
Length 3050	550
Length 2550	Single
Length 2050	Description
Length 1250	500
Length 1050	300
Version A	200
Description	Horn right
Length 2050	Horn Left
Length 1250	100
Length 1050	50
	45
	40
	35
	30
	25

Dimensions in mm

Modified Punch Tip Radii									
R0.5	R1.6	R2	R2.3	R2.5	R3	R3.2	R4	Radius	
28°	28°	28°	28°	28°	28°	28°	28°	Angle	
219.8	217.8	216	215.6	214	212.8	212.7	209.8	Height	

Punches - Pointed/Bottoming

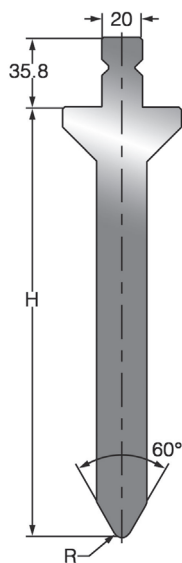

Toolspress Profile	TOW203S
Trumpf Profile	OW203/S
Radius	R4
Angle	60°
Height	220
Maximum Loading:	2500 kN/m
Weight:	52.1 kg/m

Version B	Sectionalised
Description	Description
Length 4050	250
Length 3050	550
Length 2550	Single
Length 2050	Description
Length 1250	300
Length 1050	200
Version A	Horn right
Description	Horn Left
Length 2050	100
Length 1250	50
Length 1050	45
	40
	35
	30
	25

Dimensions in mm

Modified Punch Tip Radii									
R2	R2.5	R3	R4.7	R5	R6	R6.35	R8	R10	Radius
60°	60°	60°	60°	60°	60°	60°	60°	28°	Angle
219.8	219.8	219.8	219	218.6	217.6	217.2	220	220	Height

Punches - Pointed with Flattening Spot

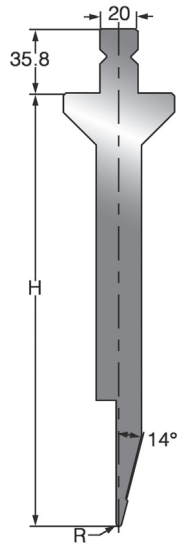

Toolspress Profile	TOW210S
Trumpf Profile	OW210/S
Radius	R1
Angle	28°
Height	240
Max. Loading (Bending):	400 kN/m
Max. Loading (Flattening):	1300 kN/m
Weight:	47.7 kg/m

Version B	Sectionalised
Description	Description
Length 4050	250
Length 3050	550
Length 2550	Single
Length 2050	Description
Length 1250	500
Length 1050	300
Version A	200
Description	Horn right
Length 2050	Horn Left
Length 1250	100
Length 1050	50
	45
	40
	35
	30
	25

Dimensions in mm

Modified Punch Tip Radii	
R0.5	Radius
28°	Angle
239.8	Height

Radius Punches

- Hardened Holders and Inserts
- Standard Radius Sizes up to 40mm
- Insert Holder made in 42CrMo4 hardened and ground
- Insert Radius made in C50 hardened and ground

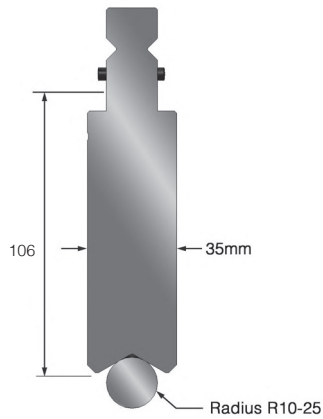

Toolspress Profile	TOW308
Trumpf Profile	OW308/K
Radius	10-25
Height	106
Maximum Loading:	1300 kN/m
Weight:	33.3 kg/m

Version B	Sectionalised
Description	Description
Length 4050	250
Length 3050	550
Length 2550	Single
Length 2050	Description
Length 1250	500
Length 1050	300
Version A	200
Description	Horn right
Length 2050	Horn Left
Length 1250	100
Length 1050	50
	45
	40
	35
	30
	25

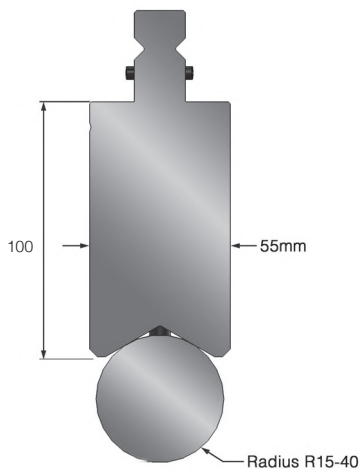

Toolspress Profile	TOW308S
Trumpf Profile	OW308/S
Radius	15-40
Height	100
Maximum Loading:	1500 kN/m
Weight:	46.5 kg/m

Version B	Sectionalised
Description	Description
Length 4050	250
Length 3050	550
Length 2550	Single
Length 2050	Description
Length 1250	500
Length 1050	300
Version A	200
Description	Horn right
Length 2050	Horn Left
Length 1250	100
Length 1050	50
	45
	40
	35
	30
	25

Standard Radius insert

10	15	20	25	30	35	40
----	----	----	----	----	----	----

Other Radius inserts available on request

Bend Limit Graph

TOW200 Swan-Neck Punch

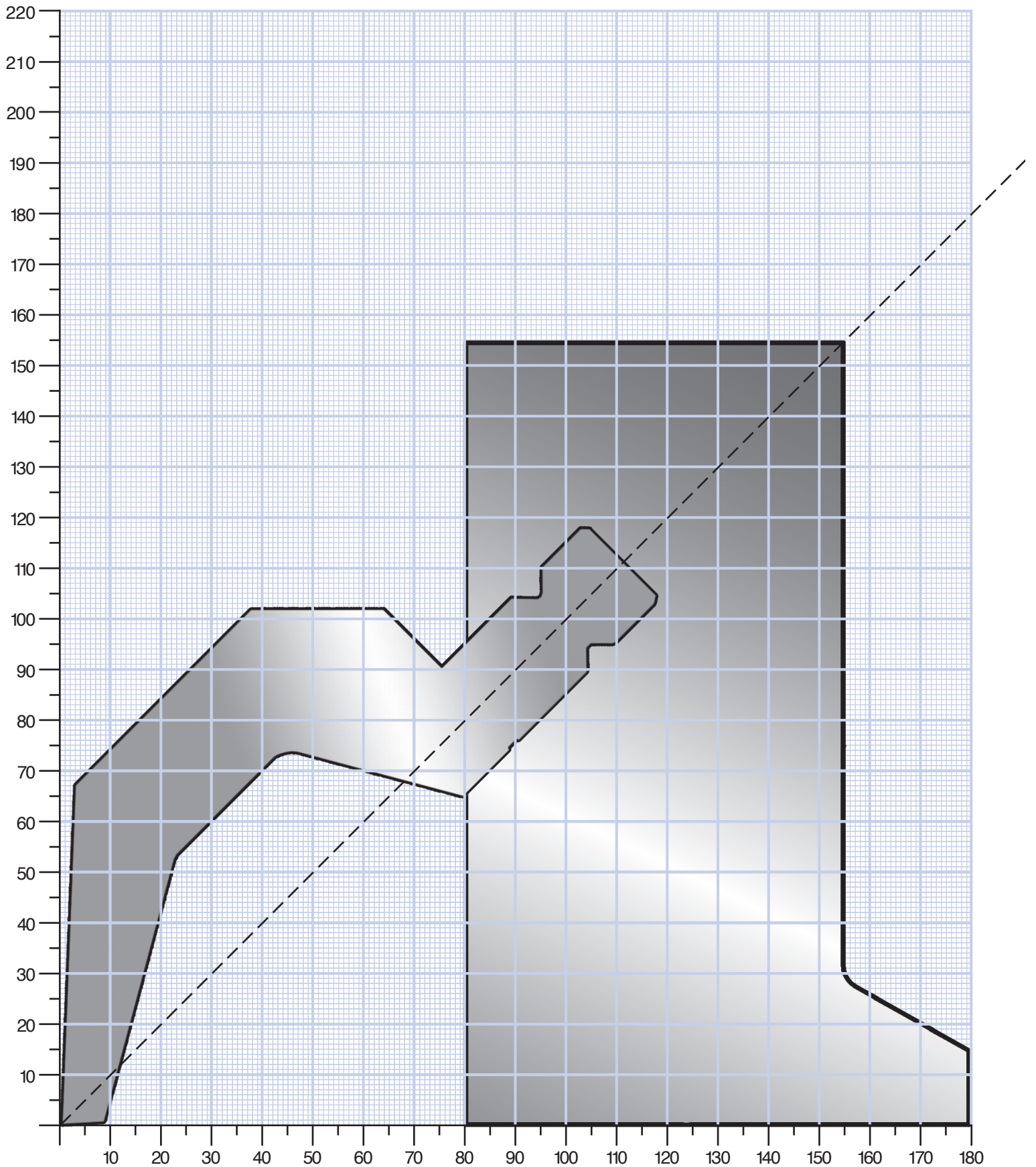

Bend Limit Graph

TOW280 Thin Tip Punch

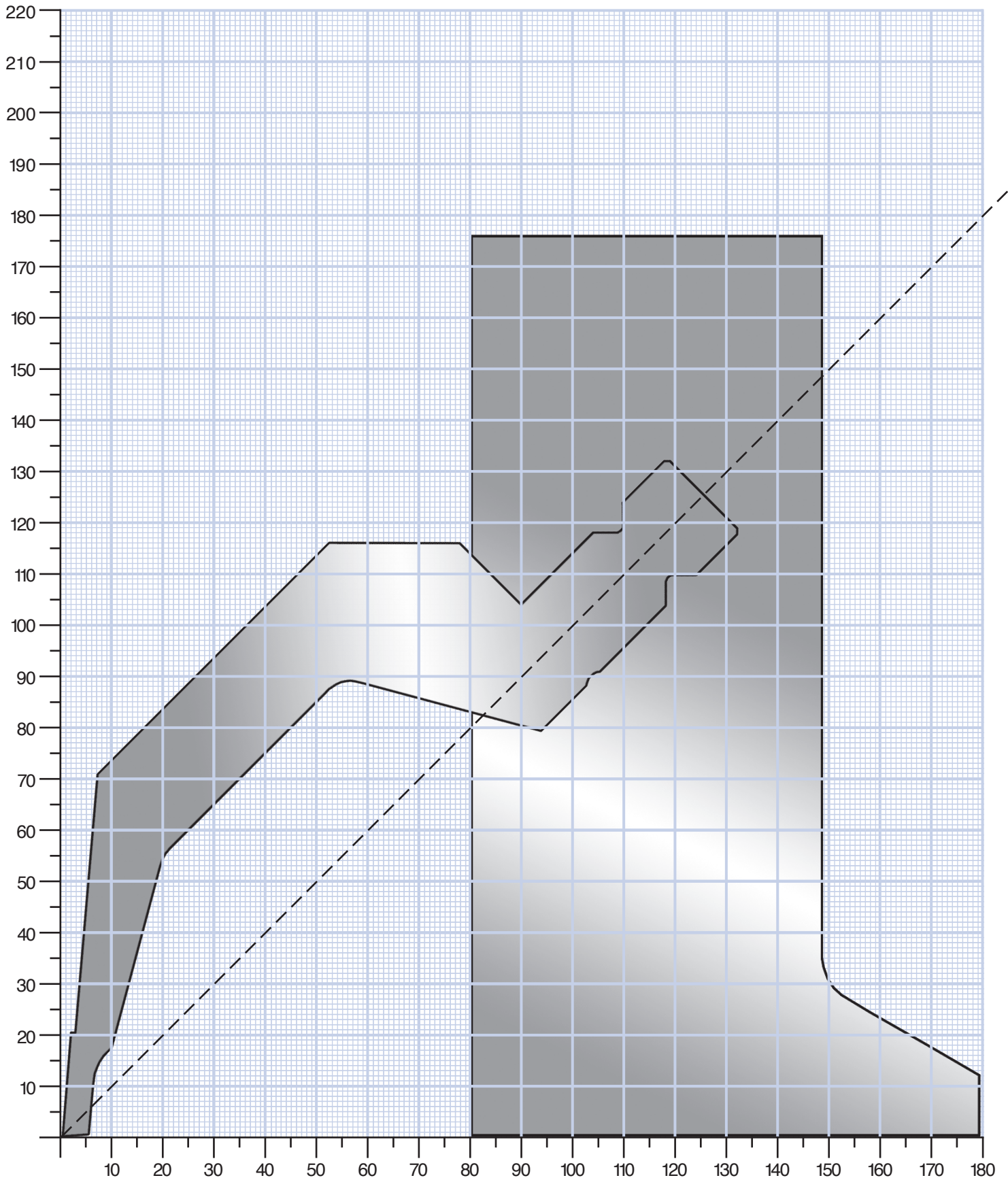

Bend Limit Graph

TOW201 Goose-Neck Punch

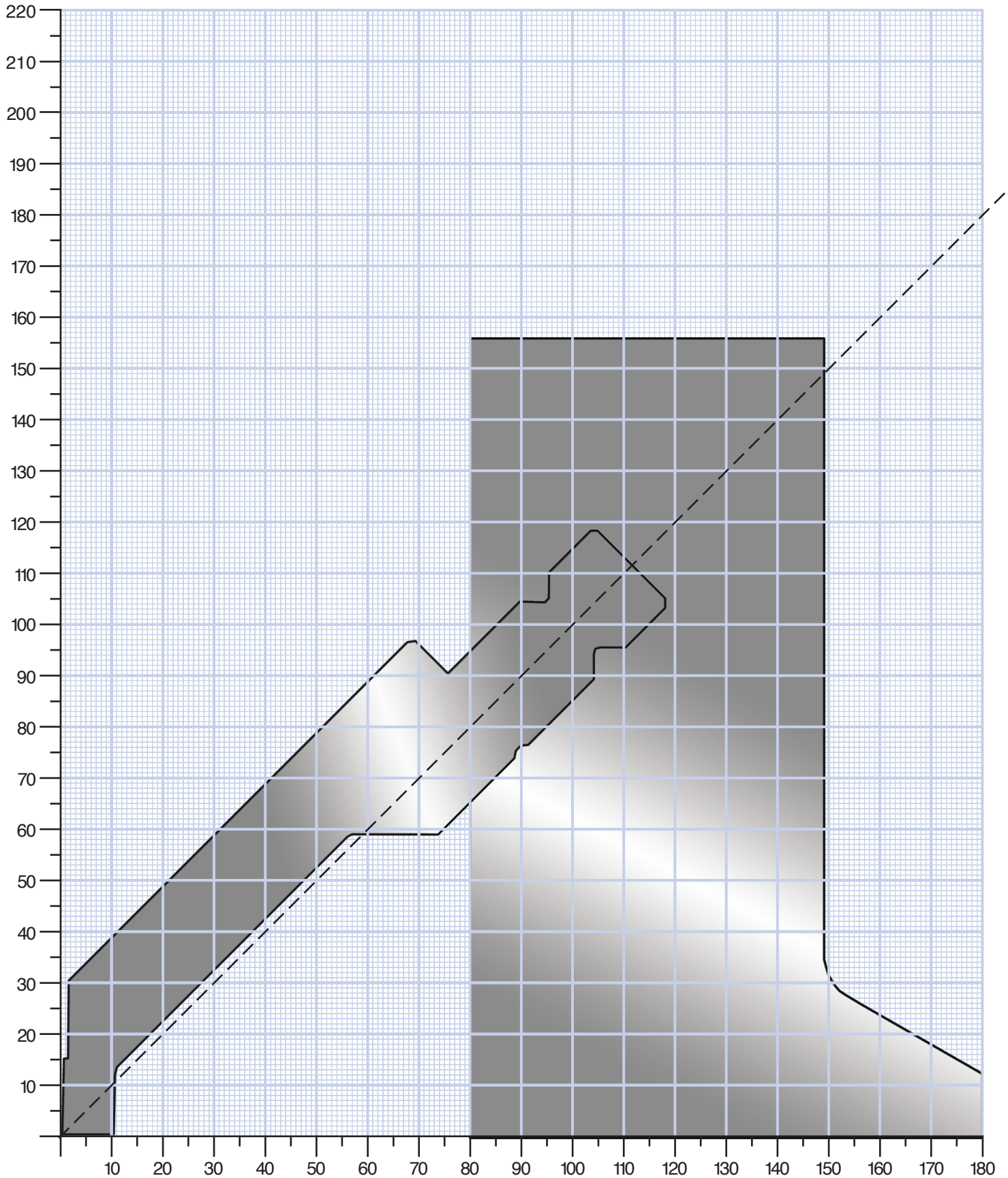

Bend Limit Graph

TOW202 Pointed with Recess Punch

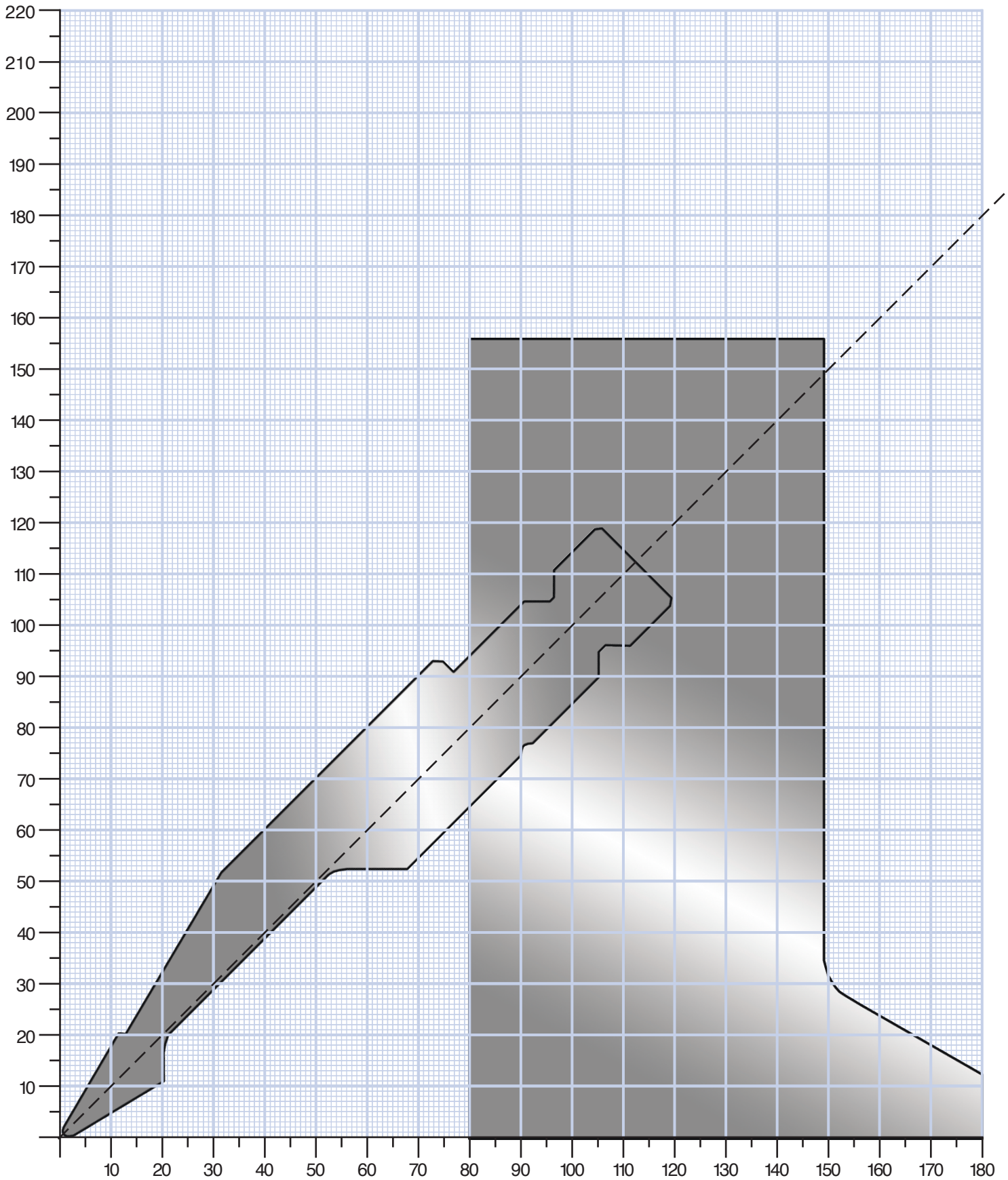

Bend Limit Graph

TOW203 Pointed/Bottoming Punch

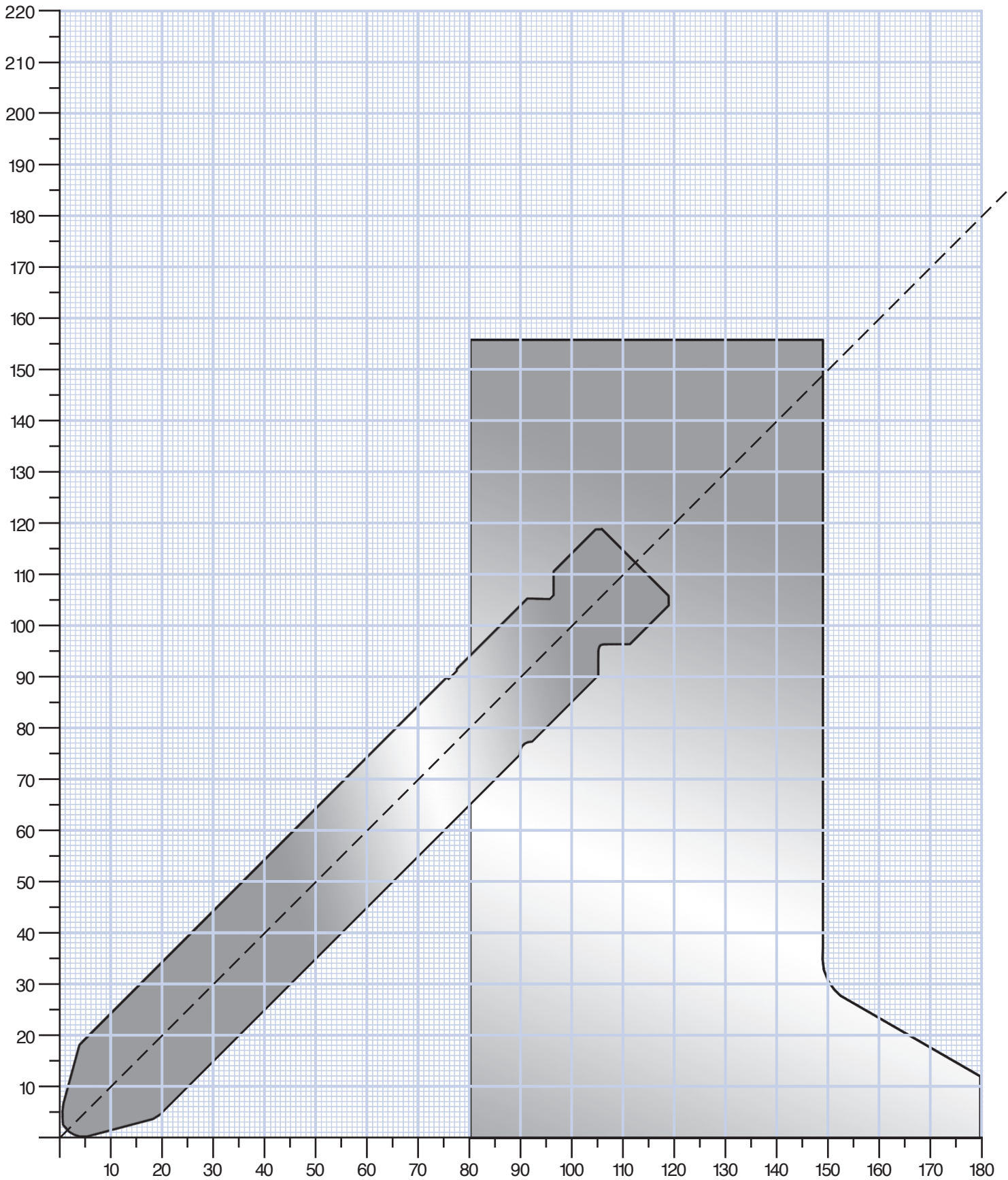

Bend Limit Graph

TOW210 Pointed with Flattened Spot Punch

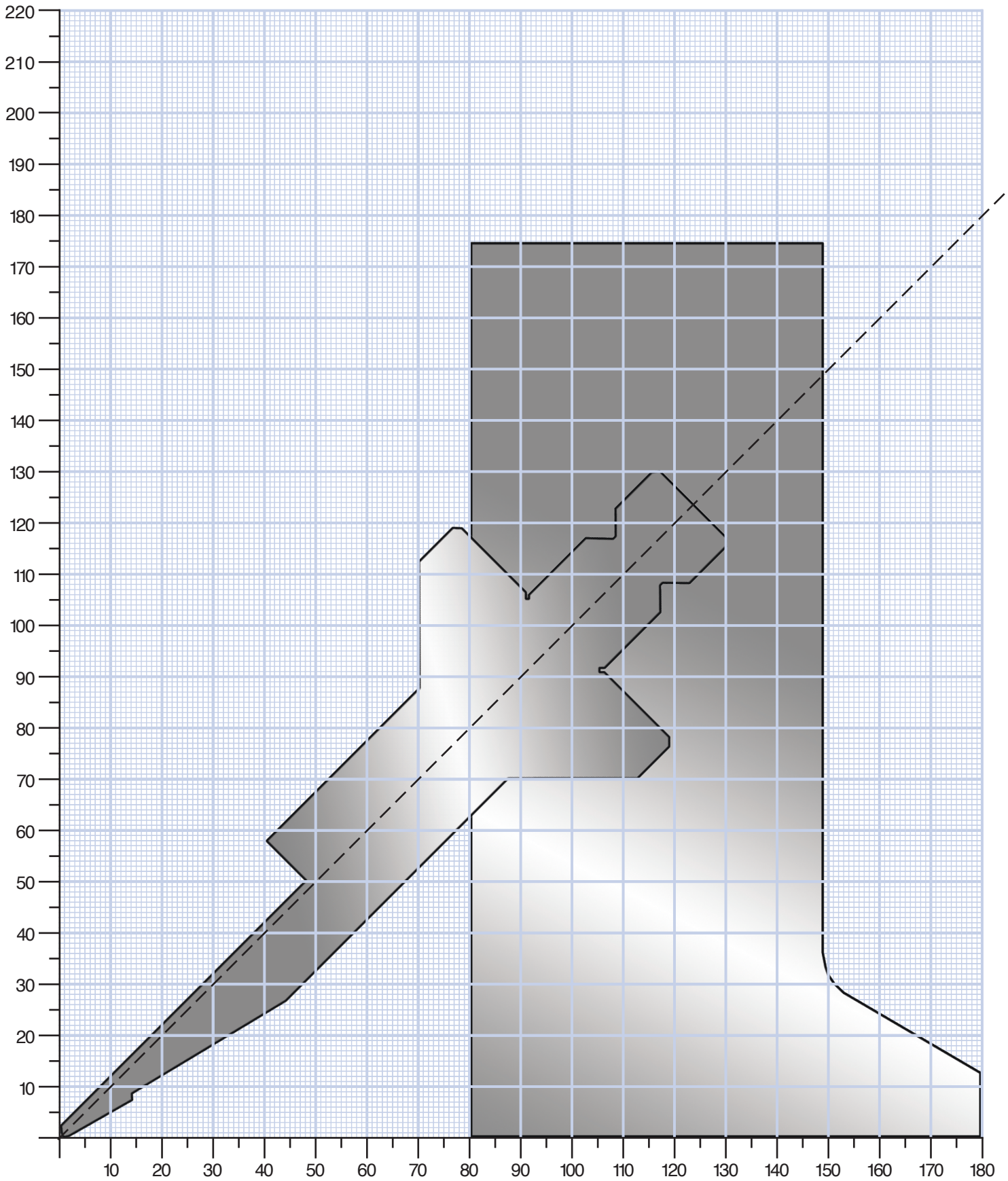

Bend Limit Graph

TOW200S Swan-Neck Punch

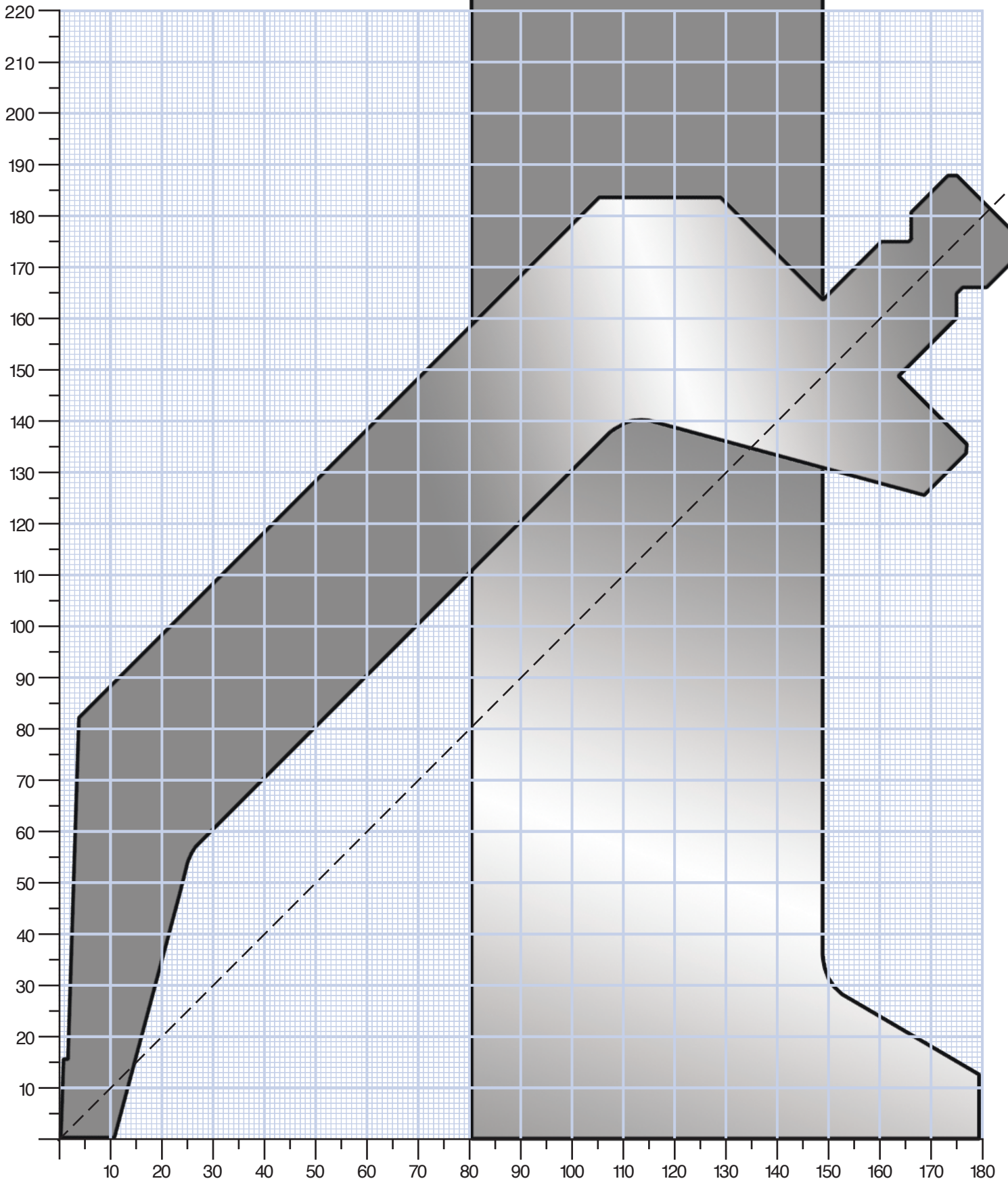

Bend Limit Graph

TOW201S Goose-Neck Punch

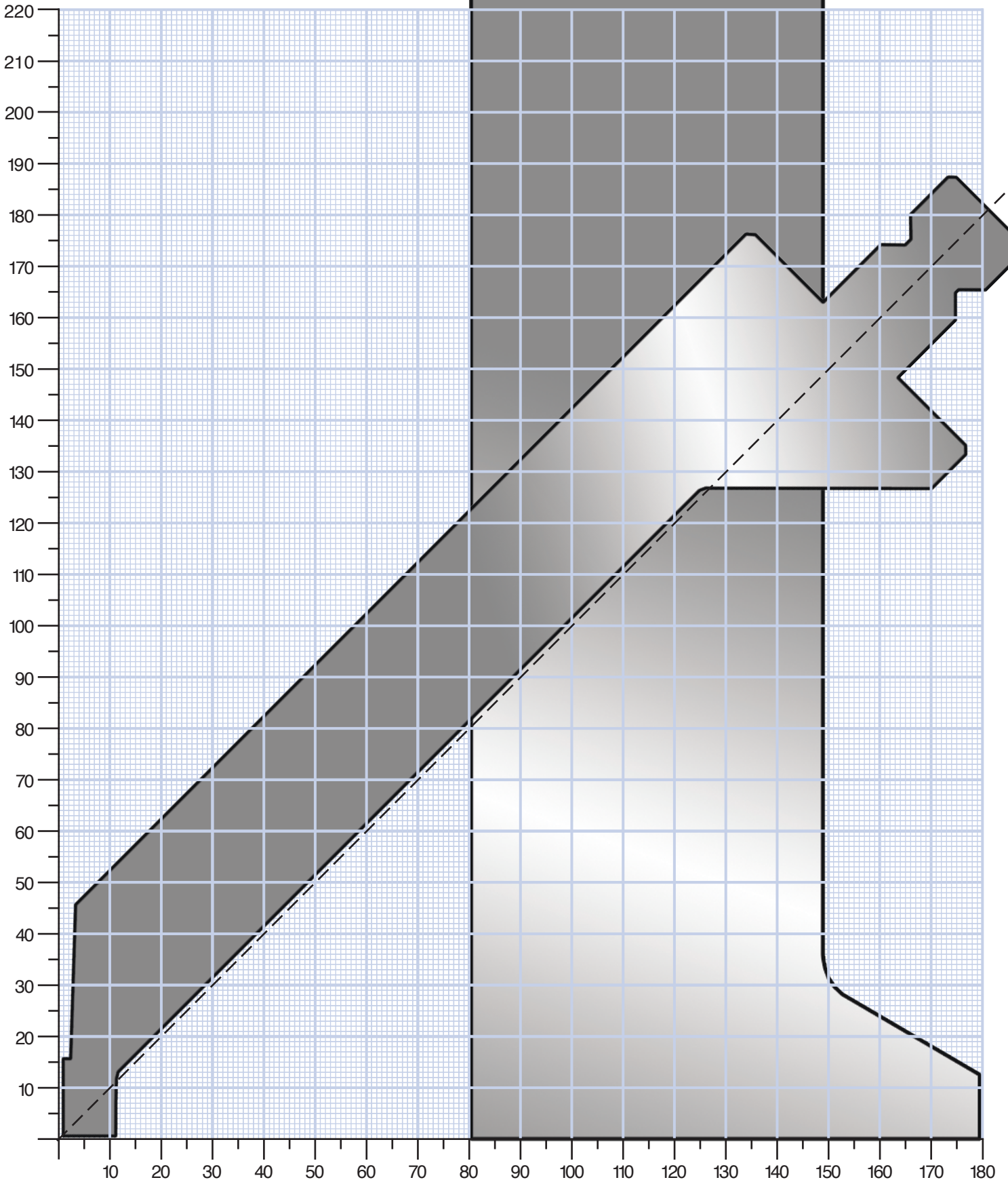

Bend Limit Graph

TOW202S Pointed with Recess Punch

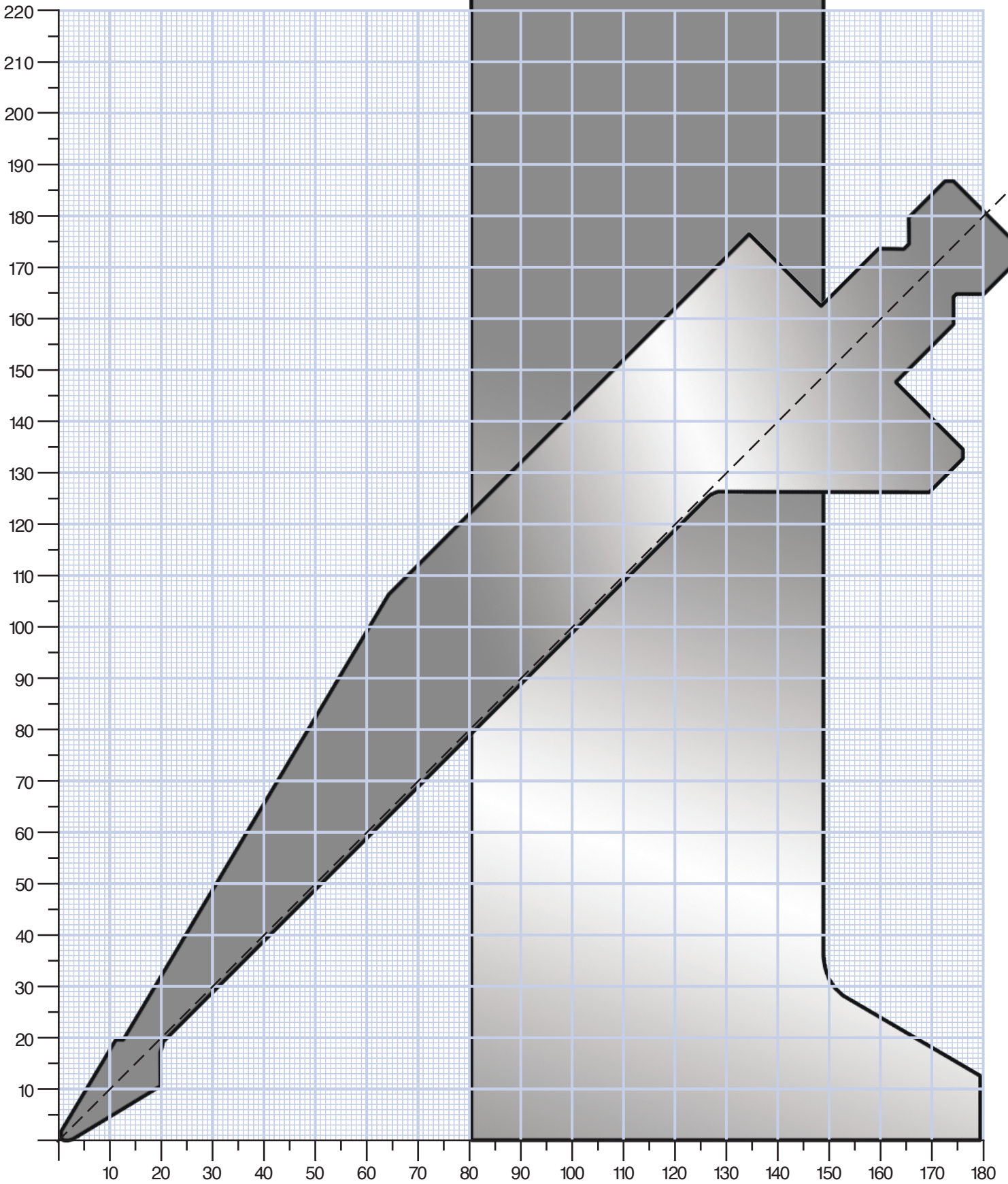

Bend Limit Graph

TOW203S Pointed/Bottoming Punch

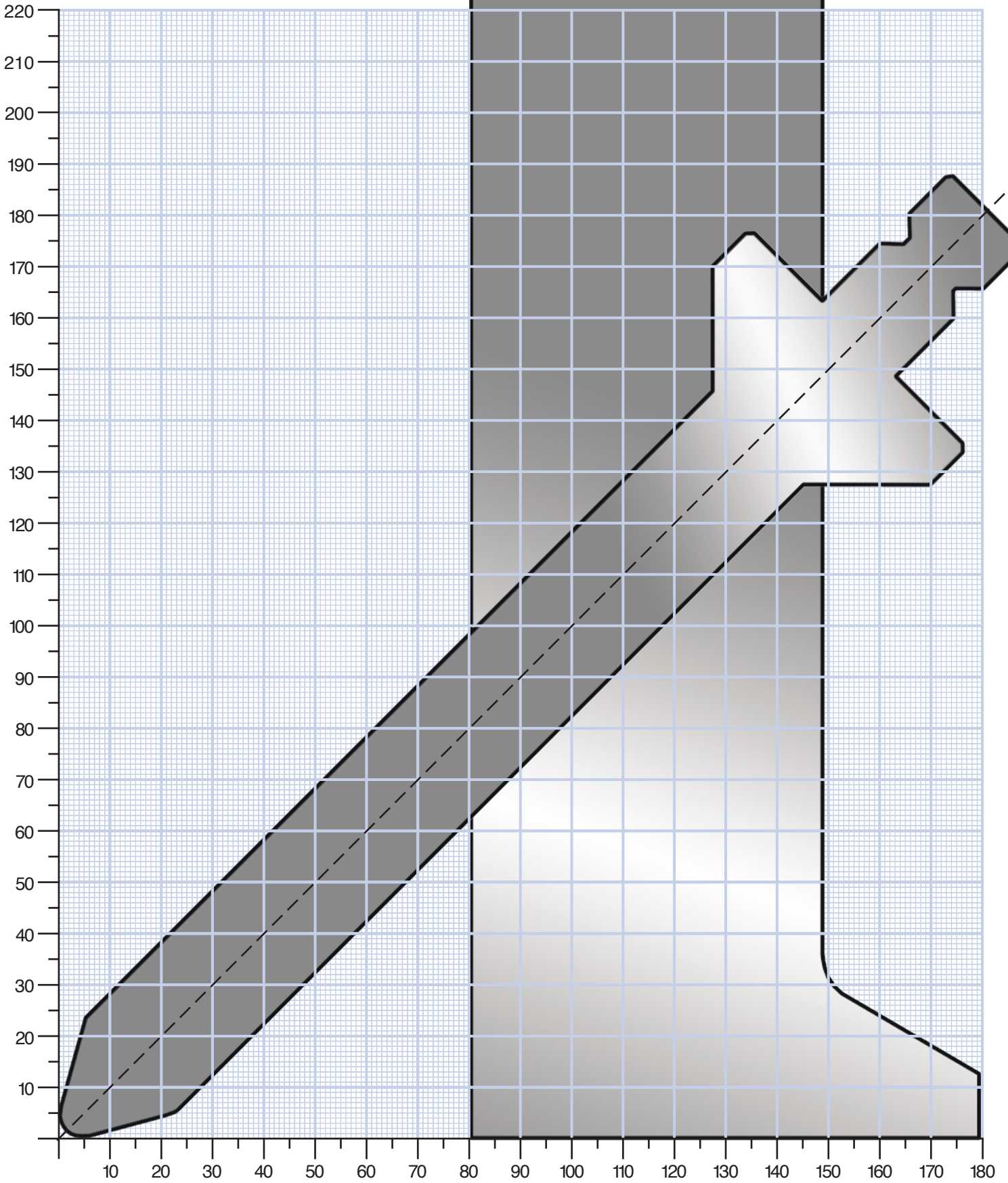

Bend Limit Graph

TOW210S Pointed with Flattened Spot

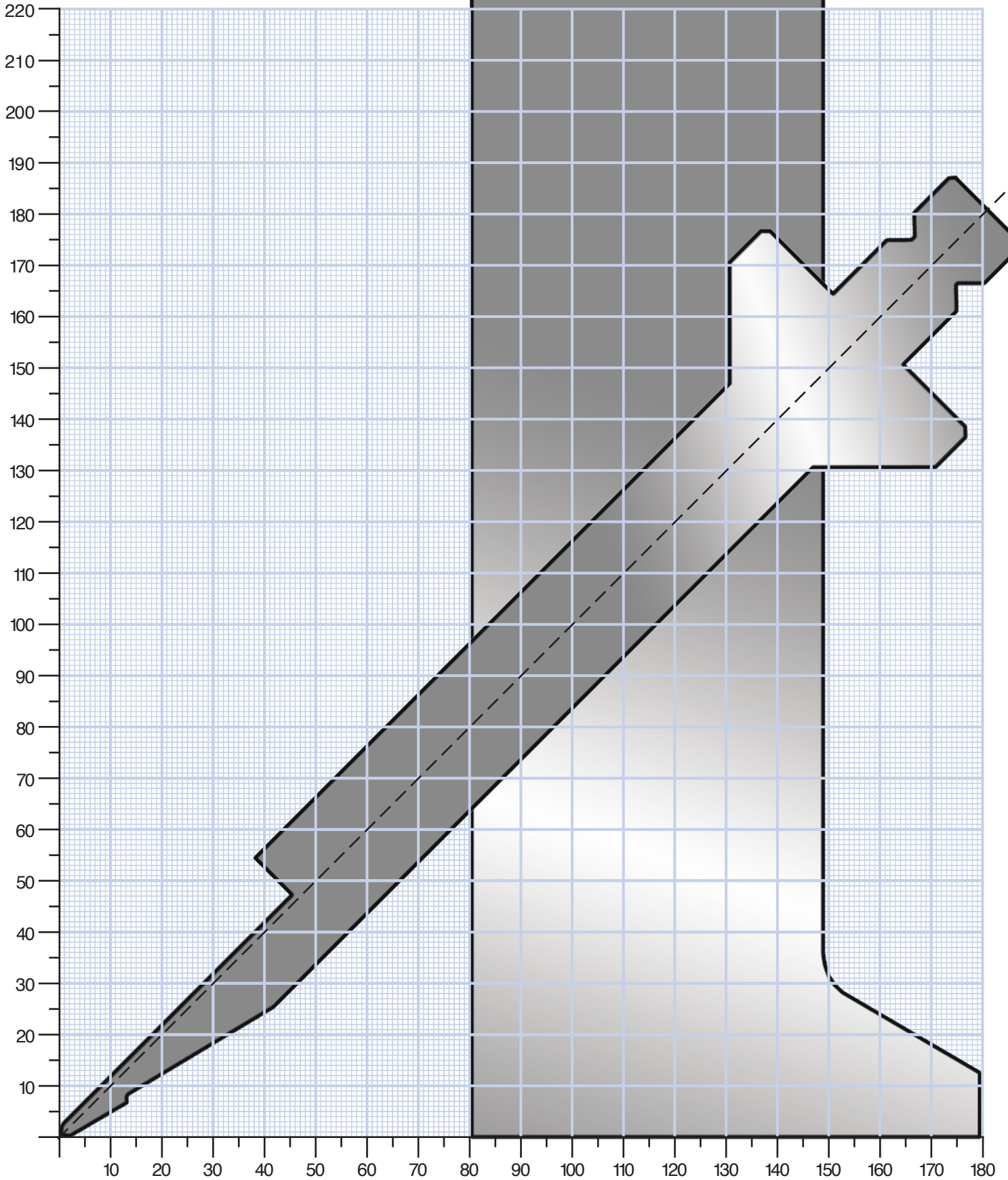

Die V-Opening = 4mm & 5mm

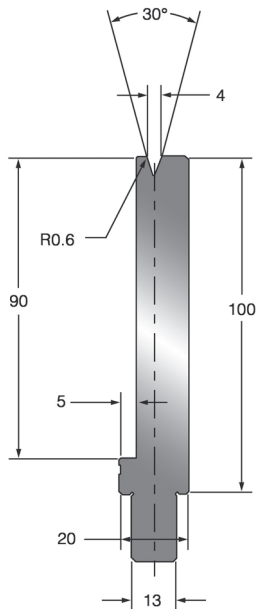

Toolspress Profile	T04S.30°
Trumpf Cat. No.	EV/S-W4/30°
V-Opening	4
Angle	30°
Height	100
Maximum Loading:	150 kN/m
Weight:	14.0 kg/m

Version B	Sectionalised
Description	Description
Length 4050	Length 250
Length 3050	Length 550
Length 2550	Single
Length 2050	Description
Length 1250	500
Length 1050	300
Version A	200
Description	100
Length 2050	50
Length 1250	45
Length 1050	40
	35
	30
	25

Bolt Holes Standard

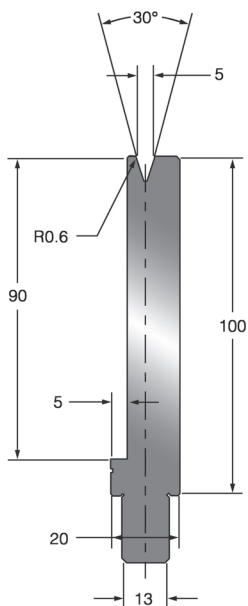

Toolspress Profile	T05S.30°
Trumpf Cat. No.	EV/S-W5/30°
V-Opening	5
Angle	30°
Height	100
Maximum Loading:	150 kN/m
Weight:	13.9 kg/m

Version B	Sectionalised
Description	Description
Length 4050	Length 250
Length 3050	Length 550
Length 2550	Single
Length 2050	Description
Length 1250	500
Length 1050	300
Version A	200
Description	100
Length 2050	50
Length 1250	45
Length 1050	40
	35
	30
	25

Dimensions in mm

Bolt Holes Standard

Die V-Opening = 4mm & 5mm

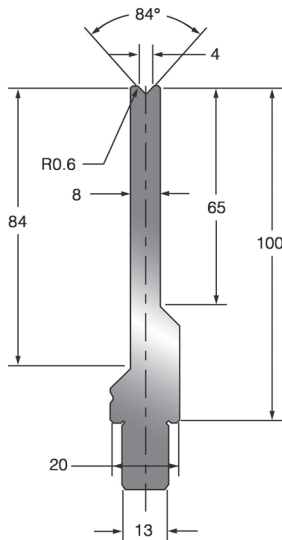

Toolspress Profile	T04S.84°
Trumpf Cat. No.	EV/S-W4/84°
V-Opening	4
Angle	84°
Height	100
Maximum Loading:	250 kN/m
Weight:	10.3 kg/m

Version B	Sectionalised
Description	Description
Length 4050	Length 250
Length 3050	Length 550
Length 2550	Single
Length 2050	Description
Length 1250	500
Length 1050	300
Version A	200
Description	100
Length 2050	50
Length 1250	45
Length 1050	40
	35
	30
	25

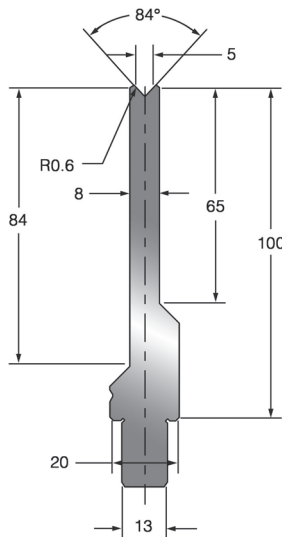

Toolspress Profile	T05S.84°
Trumpf Cat. No.	EV/S-W5/84°
V-Opening	5
Angle	84°
Height	100
Maximum Loading:	250 kN/m
Weight:	10.2 kg/m

Version B	Sectionalised
Description	Description
Length 4050	Length 250
Length 3050	Length 550
Length 2550	Single
Length 2050	Description
Length 1250	500
Length 1050	300
Version A	200
Description	100
Length 2050	50
Length 1250	45
Length 1050	40
	35
	30
	25

Dimensions in mm

Die V-Opening = 4mm & 5mm

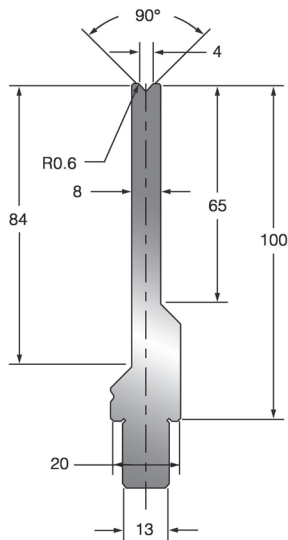

Toolspress Profile	T04S.90°
Trumpf Cat. No.	EV/S-W4/90°
V-Opening	4
Angle	90°
Height	100
Maximum Loading:	250 kN/m
Weight:	10.8 kg/m

Version B	Sectionalised
Description	Description
Length 4050	Length 250
Length 3050	Length 550
Length 2550	Single
Length 2050	Description
Length 1250	500
Length 1050	300
Version A	200
Description	100
Length 2050	50
Length 1250	45
Length 1050	40
	35
	30
	25

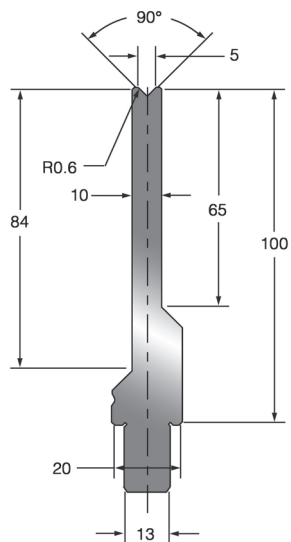

Toolspress Profile	T05S.90°
Trumpf Cat. No.	EV/S-W5/90°
V-Opening	5
Angle	90°
Height	100
Maximum Loading:	390 kN/m
Weight:	11.9 kg/m

Version B	Sectionalised
Description	Description
Length 4050	Length 250
Length 3050	Length 550
Length 2550	Single
Length 2050	Description
Length 1250	500
Length 1050	300
Version A	200
Description	100
Length 2050	50
Length 1250	45
Length 1050	40
	35
	30
	25

Dimensions in mm

Die V-Opening = 6mm

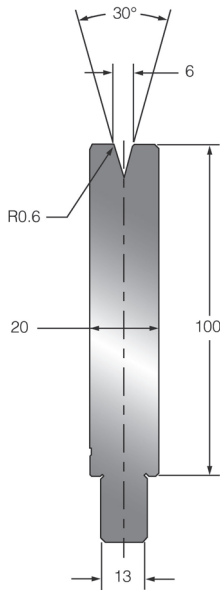

Toolspress Profile	T06.30°
Trumpf Cat. No.	EV001 30°
V-Opening	6
Angle	30°
Height	100
Maximum Loading:	400 kN/m
Weight:	17.3 kg/m

Version B	Sectionalised
Description	Description
Length 4050	Length 250
Length 3050	Length 550
Length 2550	Single
Length 2050	Description
Length 1250	500
Length 1050	300
Version A	200
Description	100
Length 2050	50
Length 1250	45
Length 1050	40
	35
	30
	25

Mod. T06.30° also available with H=150

Bolt Holes Standard

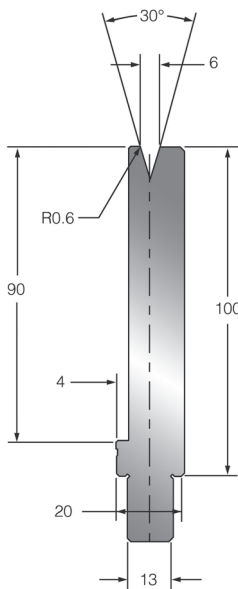

Toolspress Profile	T06S.30°
Trumpf Cat. No.	EV001/S 30°
V-Opening	6
Angle	30°
Height	100
Maximum Loading:	170 kN/m
Weight:	14.5 kg/m

Version B	Sectionalised
Description	Description
Length 4050	Length 250
Length 3050	Length 550
Length 2550	Single
Length 2050	Description
Length 1250	500
Length 1050	300
Version A	200
Description	100
Length 2050	50
Length 1250	45
Length 1050	40
	35
	30
	25

Dimensions in mm

Bolt Holes Standard

Die V-Opening = 6mm

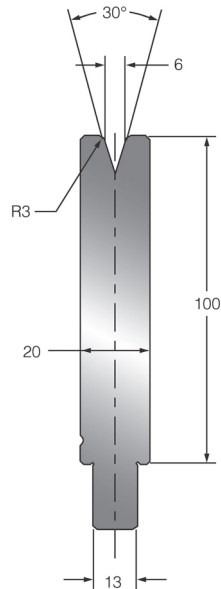

Toolspress Profile	T06.30° R3
Trumpf Cat. No.	EV001 R3 30°
V-Opening	6
Angle	30°
Height	100
Maximum Loading:	400 kN/m
Weight:	17.2 kg/m

Version B	Sectionalised
Description	Description
Length 4050	Length 250
Length 3050	Length 550
Length 2550	Single
Length 2050	Description
Length 1250	500
Length 1050	300
Version A	200
Description	100
Length 2050	50
Length 1250	45
Length 1050	40
	35
	30
	25

Bolt Holes Standard

Dimensions in mm

Die V-Opening = 6mm

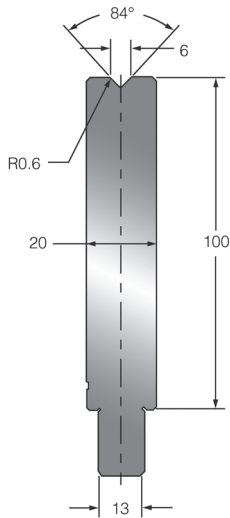

Toolspress Profile	T06.84°
Trumpf Cat. No.	EV W6 84°
V-Opening	6
Angle	84°
Height	100
Maximum Loading:	400 kN/m
Weight:	17.6 kg/m

Version B	Sectionalised
Description	Description
Length 4050	Length 250
Length 3050	Length 550
Length 2550	Single
Length 2050	Description
Length 1250	500
Length 1050	300
Version A	200
Description	100
Length 2050	50
Length 1250	45
Length 1050	40
	35
	30
	25

Mod. T06.84° also available with H=150

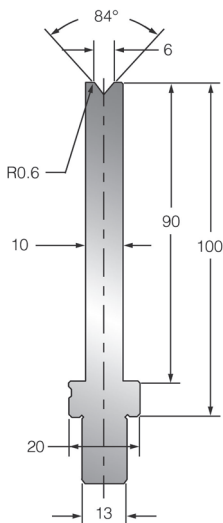

Toolspress Profile	T06S.84°
Trumpf Cat. No.	EV/S W6 84°
V-Opening	6
Angle	84°
Height	100
Maximum Loading:	250 kN/m
Weight:	10.6 kg/m

Version B	Sectionalised
Description	Description
Length 4050	Length 250
Length 3050	Length 550
Length 2550	Single
Length 2050	Description
Length 1250	500
Length 1050	300
Version A	200
Description	100
Length 2050	50
Length 1250	45
Length 1050	40
	35
	30
	25

Dimensions in mm

Die V-Opening = 6mm

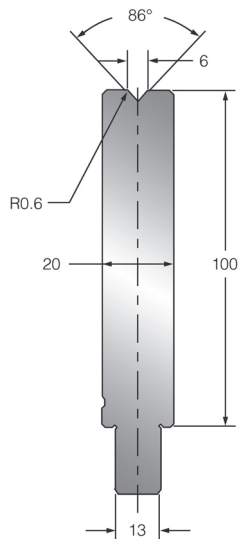

Toolspress Profile	T06.86°
Trumpf Cat. No.	EV020 86°
V-Opening	6
Angle	86°
Height	100
Maximum Loading:	400 kN/m
Weight:	17.6 kg/m

Version B	Sectionalised
Description	Description
Length 4050	Length 250
Length 3050	Length 550
Length 2550	Single
Length 2050	Description
Length 1250	500
Length 1050	300
Version A	200
Description	100
Length 2050	50
Length 1250	45
	40
	35
	30
	25

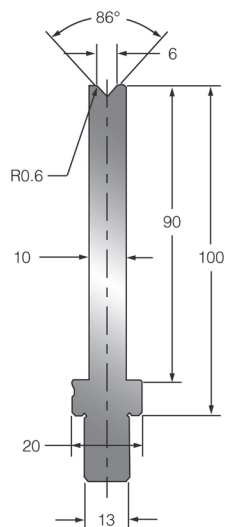

Toolspress Profile	T06S.86°
Trumpf Cat. No.	EV020/S 86°
V-Opening	6
Angle	86°
Height	100
Maximum Loading:	240 kN/m
Weight:	10.6 kg/m

Version B	Sectionalised
Description	Description
Length 4050	Length 250
Length 3050	Length 550
Length 2550	Single
Length 2050	Description
Length 1250	500
Length 1050	300
Version A	200
Description	100
Length 2050	50
Length 1250	45
	40
	35
	30
	25

Dimensions in mm

Die V-Opening = 8mm

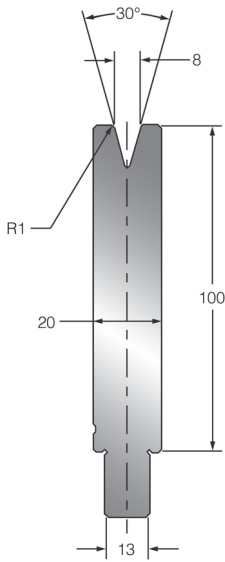

Toolspress Profile	T08.30°
Trumpf Cat. No.	EV002 30°
V-Opening	8
Angle	30°
Height	100
Maximum Loading:	400 kN/m
Weight:	17.1 kg/m

Version B	Sectionalised
Description	Description
Length 4050	Length 250
Length 3050	Length 550
Length 2550	Single
Length 2050	Description
Length 1250	500
Length 1050	300
Version A	200
Description	100
Length 2050	50
Length 1250	45
Length 1050	40
	35
	30
	25

Mod. T08.30° also available with H=150

Bolt Holes Standard

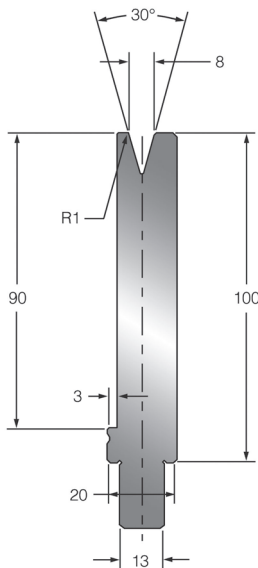

Toolspress Profile	T08S.30°
Trumpf Cat. No.	EV002/S 30°
V-Opening	8
Angle	30°
Height	100
Maximum Loading:	200 kN/m
Weight:	15.1 kg/m

Version B	Sectionalised
Description	Description
Length 4050	Length 250
Length 3050	Length 550
Length 2550	Single
Length 2050	Description
Length 1250	500
Length 1050	300
Version A	200
Description	100
Length 2050	50
Length 1250	45
Length 1050	40
	35
	30
	25

Dimensions in mm

Bolt Holes Standard

Die V-Opening = 8mm

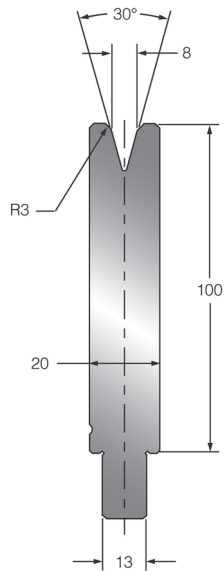

Toolspress Profile	T08.30° R3
Trumpf Cat. No.	EV002 R3 30°
V-Opening	8
Angle	30°
Height	100
Maximum Loading:	400 kN/m
Weight:	17.0 kg/m

Version B	Sectionalised
Description	Description
Length 4050	Length 250
Length 3050	Length 550
Length 2550	Single
Length 2050	Description
Length 1250	500
Length 1050	300
Version A	200
Description	100
Length 2050	50
Length 1250	45
Length 1050	40
	35
	30
	25

Bolt Holes Standard

Dimensions in mm

Die V-Opening = 8mm

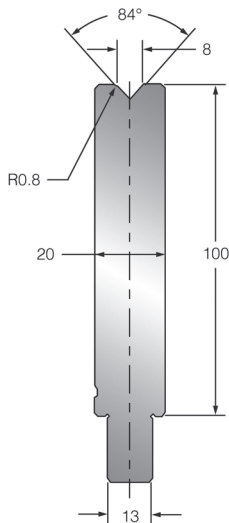

Toolspress Profile	T08.84°
Trumpf Cat. No.	EV W8/84°
V-Opening	8
Angle	84°
Height	100
Maximum Loading:	400 kN/m
Weight:	17.5 kg/m

Version B	Sectionalised
Description	Description
Length 4050	Length 250
Length 3050	Length 550
Length 2550	Single
Length 2050	Description
Length 1250	500
Length 1050	300
Version A	200
Description	100
Length 2050	50
Length 1250	45
Length 1050	40
	35
	30
	25

Mod. T08.84° also available with H=150

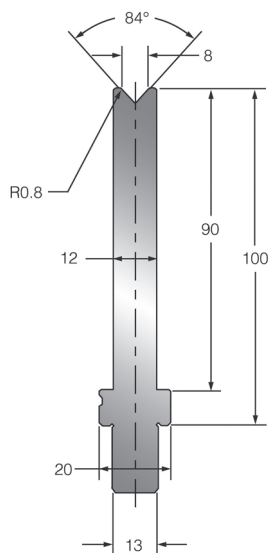

Toolspress Profile	T08S.84°
Trumpf Cat. No.	EV/S W8/84°
V-Opening	8
Angle	84°
Height	100
Maximum Loading:	350 kN/m
Weight:	11.9 kg/m

Version B	Sectionalised
Description	Description
Length 4050	Length 250
Length 3050	Length 550
Length 2550	Single
Length 2050	Description
Length 1250	500
Length 1050	300
Version A	200
Description	100
Length 2050	50
Length 1250	45
Length 1050	40
	35
	30
	25

Dimensions in mm

Die V-Opening = 8mm

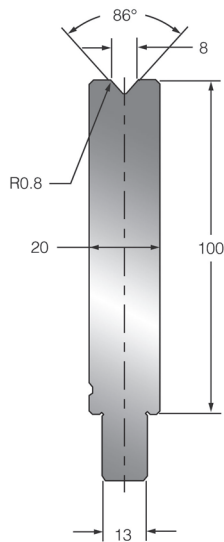

Toolspress Profile	T08.86°
Trumpf Cat. No.	EV021 86°
V-Opening	8
Angle	86°
Height	100
Maximum Loading:	400 kN/m
Weight:	17.6 kg/m

Version B	Sectionalised
Description	Description
Length 4050	Length 250
Length 3050	Length 550
Length 2550	Single
Length 2050	Description
Length 1250	500
Length 1050	300
Version A	200
Description	100
Length 2050	50
Length 1250	45
	40
	35
	30
	25

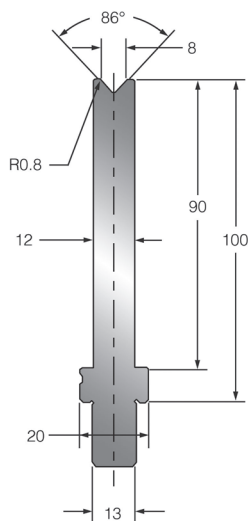

Toolspress Profile	T08S.86°
Trumpf Cat. No.	EV021/S 86°
V-Opening	8
Angle	86°
Height	100
Maximum Loading:	310 kN/m
Weight:	11.9 kg/m

Version B	Sectionalised
Description	Description
Length 4050	Length 250
Length 3050	Length 550
Length 2550	Single
Length 2050	Description
Length 1250	500
Length 1050	300
Version A	200
Description	100
Length 2050	50
Length 1250	45
	40
	35
	30
	25

Dimensions in mm

Die V-Opening = 10mm

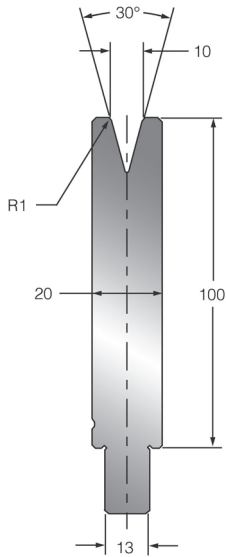

Toolspress Profile	T10.30°
Trumpf Cat. No.	EV003 30°
V-Opening	10
Angle	30°
Height	100
Maximum Loading:	400 kN/m
Weight:	16.9 kg/m

Version B	Sectionalised
Description	Description
Length 4050	Length 250
Length 3050	Length 550
Length 2550	Single
Length 2050	Description
Length 1250	500
Length 1050	300
Version A	200
Description	100
Length 2050	50
Length 1250	45
Length 1050	40
	35
	30
	25

Mod. T10.30° also available with H=150

Bolt Holes Standard

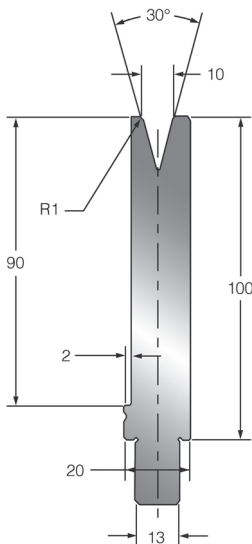

Toolspress Profile	T10S.30°
Trumpf Cat. No.	EV003/S 30°
V-Opening	10
Angle	30°
Height	100
Maximum Loading:	200 kN/m
Weight:	15.5 kg/m

Version B	Sectionalised
Description	Description
Length 4050	Length 250
Length 3050	Length 550
Length 2550	Single
Length 2050	Description
Length 1250	500
Length 1050	300
Version A	200
Description	100
Length 2050	50
Length 1250	45
Length 1050	40
	35
	30
	25

Dimensions in mm

Bolt Holes Standard

Die V-Opening = 10mm

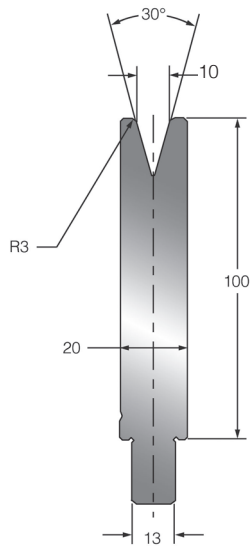

Toolspress Profile	T10.30° R3
Trumpf Cat. No.	EV003 R3 30°
V-Opening	10
Angle	30°
Height	100
Maximum Loading:	400 kN/m
Weight:	16.7 kg/m

Version B	Sectionalised
Description	Description
Length 4050	Length 250
Length 3050	Length 550
Length 2550	Single
Length 2050	Description
Length 1250	500
Length 1050	300
Version A	200
Description	100
Length 2050	50
Length 1250	45
Length 1050	40
	35
	30
	25

Bolt Holes Standard

Dimensions in mm

Die V-Opening = 10mm

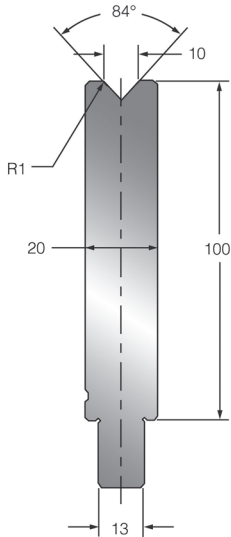

Toolspress Profile	T10.84°
Trumpf Cat. No.	EV W10/84°
V-Opening	10
Angle	84°
Height	100
Maximum Loading:	500 kN/m
Weight:	17.5 kg/m

Version B	Sectionalised
Description	Description
Length 4050	Length 250
Length 3050	Length 550
Length 2550	Single
Length 2050	Description
Length 1250	500
Length 1050	300
Version A	200
Description	100
Length 2050	50
Length 1250	45
Length 1050	40
	35
	30
	25

Mod. T10.84° also available with H=150

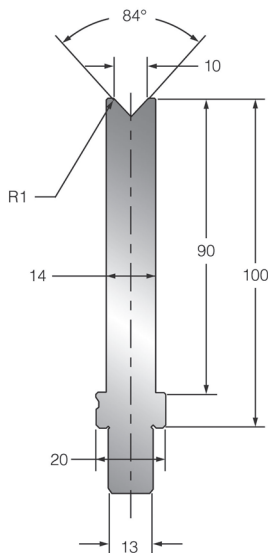

Toolspress Profile	T10S.84°
Trumpf Cat. No.	EV/S W10/84°
V-Opening	10
Angle	84°
Height	100
Maximum Loading:	400 kN/m
Weight:	13.3 kg/m

Version B	Sectionalised
Description	Description
Length 4050	Length 250
Length 3050	Length 550
Length 2550	Single
Length 2050	Description
Length 1250	500
Length 1050	300
Version A	200
Description	100
Length 2050	50
Length 1250	45
Length 1050	40
	35
	30
	25

Dimensions in mm

Die V-Opening = 10mm

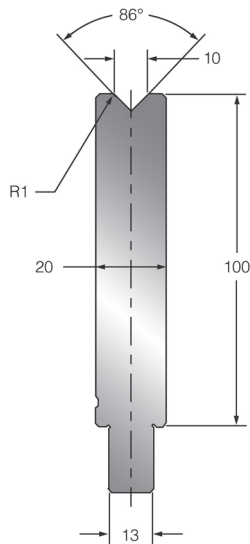

Toolspress Profile	T10.86°
Trumpf Cat. No.	EV022 86°
V-Opening	10
Angle	86°
Height	100
Maximum Loading:	500 kN/m
Weight:	17.5 kg/m

Version B	Sectionalised
Description	Description
Length 4050	Length 250
Length 3050	Length 550
Length 2550	Single
Length 2050	Description
Length 1250	500
Length 1050	300
Version A	200
Description	100
Length 2050	50
Length 1250	45
	40
	35
	30
	25

Mod. T10.86° also available with H=150

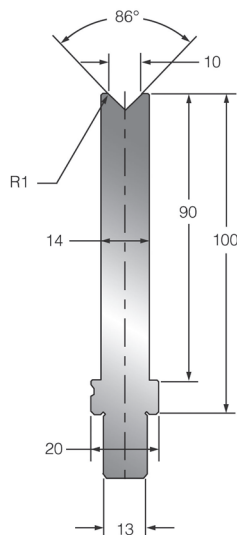

Toolspress Profile	T10S.86°
Trumpf Cat. No.	EV022/S 86°
V-Opening	10
Angle	86°
Height	100
Maximum Loading:	380 kN/m
Weight:	13.3 kg/m

Version B	Sectionalised
Description	Description
Length 4050	Length 250
Length 3050	Length 550
Length 2550	Single
Length 2050	Description
Length 1250	500
Length 1050	300
Version A	200
Description	100
Length 2050	50
Length 1250	45
	40
	35
	30
	25

Dimensions in mm

Die V-Opening = 12mm

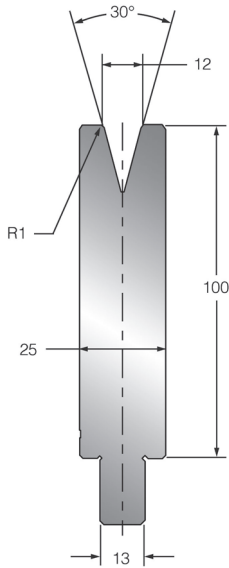

Toolspress Profile	T12.30°
Trumpf Cat. No.	EV004 30°
V-Opening	12
Angle	30°
Height	100
Maximum Loading:	400 kN/m
Weight:	20.5 kg/m

Version B	Sectionalised
Description	Description
Length 4050	Length 250
Length 3050	Length 550
Length 2550	Single
Length 2050	Description
Length 1250	500
Length 1050	300
Version A	200
Description	100
Length 2050	50
Length 1250	45
Length 1050	40
	35
	30
	25

Mod. T12.30° also available with H=150

Bolt Holes Standard

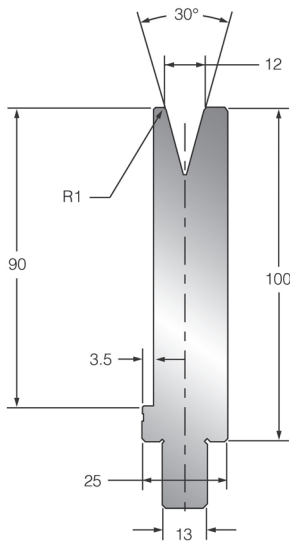

Toolspress Profile	T12S.30°
Trumpf Cat. No.	EV004/S 30°
V-Opening	12
Angle	30°
Height	100
Maximum Loading:	250 kN/m
Weight:	18.0 kg/m

Version B	Sectionalised
Description	Description
Length 4050	Length 250
Length 3050	Length 550
Length 2550	Single
Length 2050	Description
Length 1250	500
Length 1050	300
Version A	200
Description	100
Length 2050	50
Length 1250	45
Length 1050	40
	35
	30
	25

Dimensions in mm

Bolt Holes Standard

Die V-Opening = 12mm

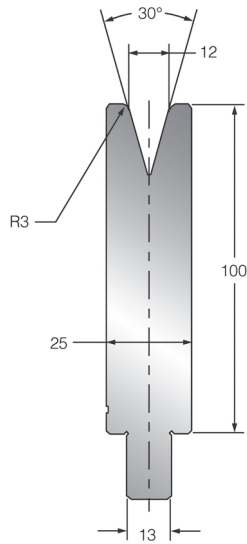

Toolspress Profile	T12.30° R3
Trumpf Cat. No.	EV004 R3 30°
V-Opening	12
Angle	30°
Height	100
Maximum Loading:	400 kN/m
Weight:	20.3 kg/m

Version B	Sectionalised
Description	Description
Length 4050	Length 250
Length 3050	Length 550
Length 2550	Single
Length 2050	Description
Length 1250	500
Length 1050	300
Version A	200
Description	100
Length 2050	50
Length 1250	45
Length 1050	40
	35
	30
	25

Bolt Holes Standard

Dimensions in mm

Die V-Opening = 12mm

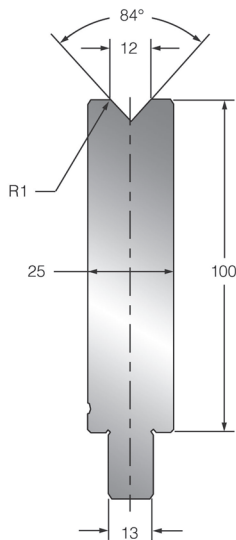

Toolspress Profile	T12.84°
Trumpf Cat. No.	EV W12/84°
V-Opening	12
Angle	84°
Height	100
Maximum Loading:	500 kN/m
Weight:	21.4 kg/m

Version B	Sectionalised
Description	Description
Length 4050	Length 250
Length 3050	Length 550
Length 2550	Single
Length 2050	Description
Length 1250	500
Length 1050	300
Version A	200
Description	100
Length 2050	50
Length 1250	45
Length 1050	40
	35
	30
	25

Mod. T12.84° also available with H=150

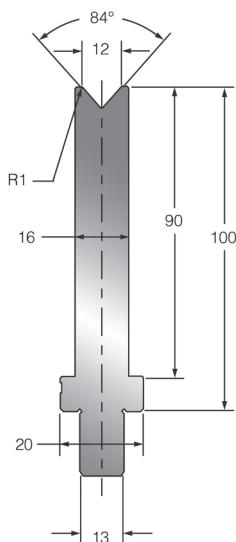

Toolspress Profile	T12S.84°
Trumpf Cat. No.	EV/S W12/84°
V-Opening	12
Angle	84°
Height	100
Maximum Loading:	400 kN/m
Weight:	14.9 kg/m

Version B	Sectionalised
Description	Description
Length 4050	Length 250
Length 3050	Length 550
Length 2550	Single
Length 2050	Description
Length 1250	500
Length 1050	300
Version A	200
Description	100
Length 2050	50
Length 1250	45
Length 1050	40
	35
	30
	25

Dimensions in mm

Die V-Opening = 12mm

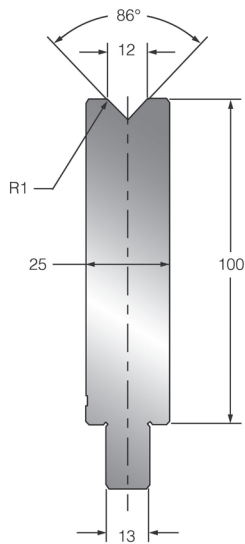

Toolspress Profile	T12.86°
Trumpf Cat. No.	EV023 86°
V-Opening	12
Angle	86°
Height	100
Maximum Loading:	500 kN/m
Weight:	21.4 kg/m

Version B	Sectionalised
Description	Description
Length 4050	Length 250
Length 3050	Length 550
Length 2550	Single
Length 2050	Description
Length 1250	500
Length 1050	300
Version A	200
Description	100
Length 2050	50
Length 1250	45
	40
	35
	30
	25

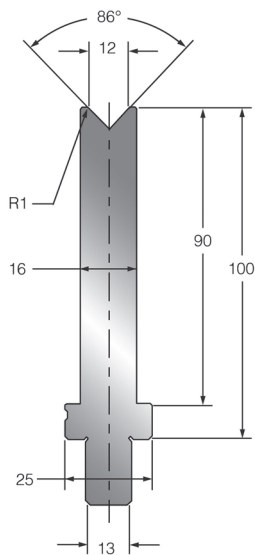

Toolspress Profile	T12S.86°
Trumpf Cat. No.	EV023/S 86°
V-Opening	12
Angle	86°
Height	100
Maximum Loading:	400 kN/m
Weight:	14.9 kg/m

Version B	Sectionalised
Description	Description
Length 4050	Length 250
Length 3050	Length 550
Length 2550	Single
Length 2050	Description
Length 1250	500
Length 1050	300
Version A	200
Description	100
Length 2050	50
Length 1250	45
	40
	35
	30
	25

Dimensions in mm

Die V-Opening = 16mm

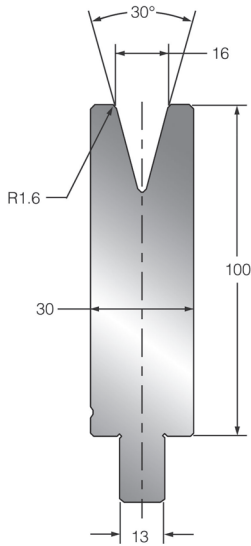

Toolspress Profile	T16.30°
Trumpf Cat. No.	EV005 30°
V-Opening	16
Angle	30°
Height	100
Maximum Loading:	500 kN/m
Weight:	23.4 kg/m

Version B	Sectionalised
Description	Description
Length 4050	Length 250
Length 3050	Length 550
Length 2550	Single
Length 2050	Description
Length 1250	500
Length 1050	300
Version A	200
Description	100
Length 2050	50
Length 1250	45
Length 1050	40
	35
	30
	25

Mod. T16.30° also available with H=150

Bolt Holes Standard

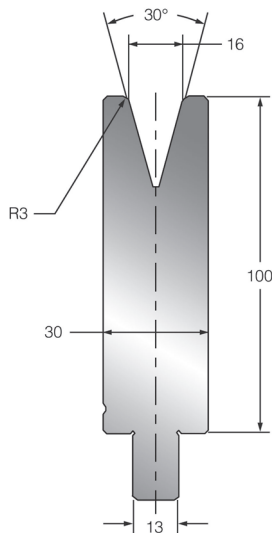

Toolspress Profile	T16.30° R3
Trumpf Cat. No.	EV005 R3 30°
V-Opening	16
Angle	30°
Height	100
Maximum Loading:	500 kN/m
Weight:	23.3 kg/m

Version B	Sectionalised
Description	Description
Length 4050	Length 250
Length 3050	Length 550
Length 2550	Single
Length 2050	Description
Length 1250	500
Length 1050	300
Version A	200
Description	100
Length 2050	50
Length 1250	45
Length 1050	40
	35
	30
	25

Dimensions in mm

Bolt Holes Standard

Die V-Opening = 16mm

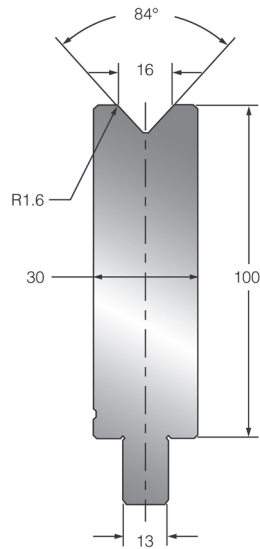

Toolspress Profile	T16.84°
Trumpf Cat. No.	EV W16/84°
V-Opening	16
Angle	84°
Height	100
Maximum Loading:	700 kN/m
Weight:	25.0 kg/m

Version B	Sectionalised
Description	Description
Length 4050	Length 250
Length 3050	Length 550
Length 2550	Single
Length 2050	Description
Length 1250	500
Length 1050	300
Version A	200
Description	100
Length 2050	50
Length 1250	45
Length 1050	40
	35
	30
	25

Mod. T16.84° also available with H=150

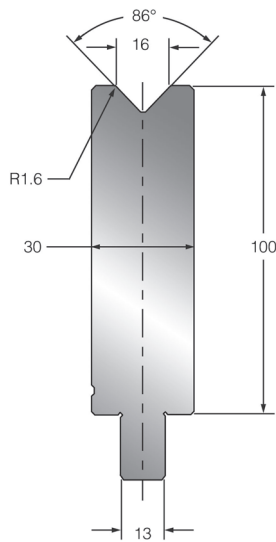

Toolspress Profile	T16.86°
Trumpf Cat. No.	EV024 86°
V-Opening	16
Angle	86°
Height	100
Maximum Loading:	700 kN/m
Weight:	25.0 kg/m

Version B	Sectionalised
Description	Description
Length 4050	Length 250
Length 3050	Length 550
Length 2550	Single
Length 2050	Description
Length 1250	500
Length 1050	300
Version A	200
Description	100
Length 2050	50
Length 1250	45
	40
	35
	30
	25

Dimensions in mm

Die V-Opening = 20mm

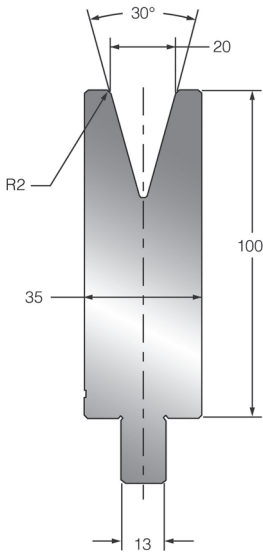

Toolspress Profile	T20.30°
Trumpf Cat. No.	EV006 30°
V-Opening	20
Angle	30°
Height	100
Maximum Loading:	600 kN/m
Weight:	26.3 kg/m

Version B	Sectionalised
Description	Description
Length 4050	Length 250
Length 3050	Length 550
Length 2550	Single
Length 2050	Description
Length 1250	500
Length 1050	300
Version A	200
Description	100
Length 2050	50
Length 1250	45
Length 1050	40
	35
	30
	25

Mod. T20.30° also available with H=150

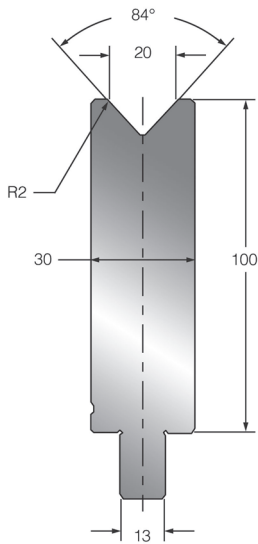

Toolspress Profile	T20.84°
Trumpf Cat. No.	EV W20/84°
V-Opening	20
Angle	84°
Height	100
Maximum Loading:	700 kN/m
Weight:	24.6 kg/m

Version B	Sectionalised
Description	Description
Length 4050	Length 250
Length 3050	Length 550
Length 2550	Single
Length 2050	Description
Length 1250	500
Length 1050	300
Version A	200
Description	100
Length 2050	50
Length 1250	45
Length 1050	40
	35
	30
	25

Mod. T20.84° also available with H=150

Dimensions in mm

Die V-Opening = 20mm

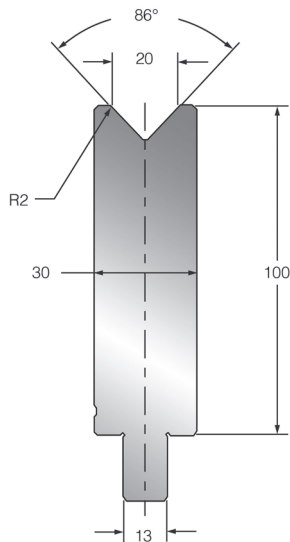

Toolspress Profile	T20.86°
Trumpf Cat. No.	EV025 86°
V-Opening	20
Angle	86°
Height	100
Maximum Loading:	700 kN/m
Weight:	24.6 kg/m

Version B	Sectionalised
Description	Description
Length 4050	Length 250
Length 3050	Length 550
Length 2550	Single
Length 2050	Description
Length 1250	500
Length 1050	300
Version A	200
Description	100
Length 2050	50
Length 1250	45
Length 1050	40
	35
	30
	25

Mod. T20.86° also available with H=150

Dimensions in mm

Die V-Opening = 24mm

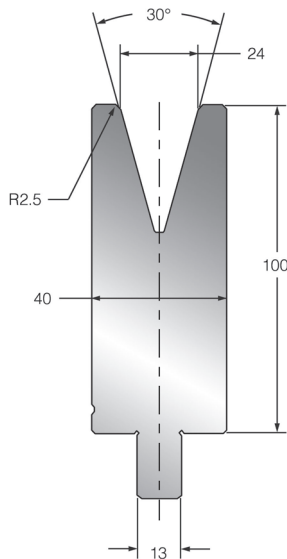

Toolspress Profile	T24.30°
Trumpf Cat. No.	EV007 30°
V-Opening	24
Angle	30°
Height	100
Maximum Loading:	650 kN/m
Weight:	29.5 kg/m

Version B	Sectionalised
Description	Description
Length 4050	Length 250
Length 3050	Length 550
Length 2550	Single
Length 2050	Description
Length 1250	500
Length 1050	300
Version A	200
Description	100
Length 2050	50
Length 1250	45
Length 1050	40
	35
	30
	25

Mod. T24.30° also available with H=150

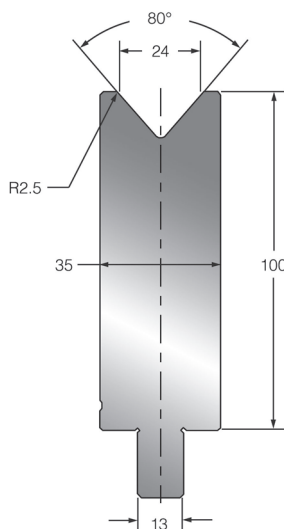

Toolspress Profile	T24.80°
Trumpf Cat. No.	EV W24/80°
V-Opening	24
Angle	80°
Height	100
Maximum Loading:	700 kN/m
Weight:	28.1 kg/m

Version B	Sectionalised
Description	Description
Length 4050	Length 250
Length 3050	Length 550
Length 2550	Single
Length 2050	Description
Length 1250	500
Length 1050	300
Version A	200
Description	100
Length 2050	50
Length 1250	45
Length 1050	40
	35
	30
	25

Mod. T24.80° also available with H=150

Dimensions in mm

Die V-Opening = 24mm

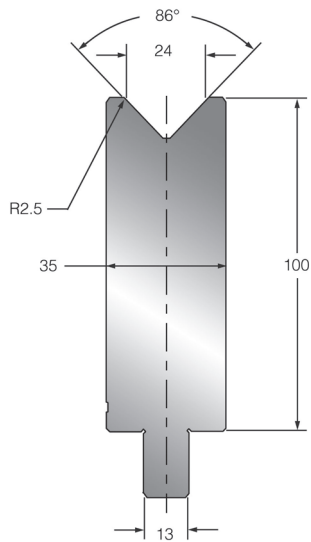

Toolspress Profile	T24.86°
Trumpf Cat. No.	EV026 86°
V-Opening	24
Angle	86°
Height	100
Maximum Loading:	700 kN/m
Weight:	28.2 kg/m

Version B	Sectionalised
Description	Description
Length 4050	Length 250
Length 3050	Length 550
Length 2550	Single
Length 2050	Description
Length 1250	500
Length 1050	300
Version A	200
Description	100
Length 2050	50
Length 1250	45
	40
	35
	30
	25

Dimensions in mm

Die V-Opening = 30mm

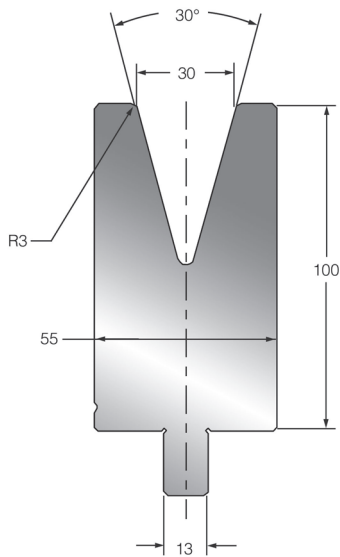

Toolspress Profile	T30.30°
Trumpf Cat. No.	EV W30/30°
V-Opening	30
Angle	30°
Height	100
Maximum Loading:	900 kN/m
Weight:	37.8 kg/m

Version B	Sectionalised
Description	Description
Length 4050	Length 250
Length 3050	Length 550
Length 2550	Single
Length 2050	Description
Length 1250	500
Length 1050	300
Version A	200
Description	100
Length 2050	50
Length 1250	45
Length 1050	40
	35
	30
	25

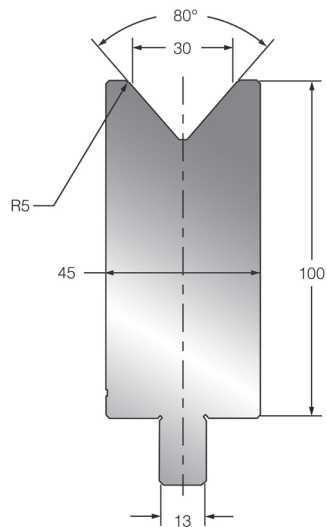

Toolspress Profile	T30.80°
Trumpf Cat. No.	EV W30/80°
V-Opening	30
Angle	80°
Height	100
Maximum Loading:	900 kN/m
Weight:	34.8 kg/m

Version B	Sectionalised
Description	Description
Length 4050	Length 250
Length 3050	Length 550
Length 2550	Single
Length 2050	Description
Length 1250	500
Length 1050	300
Version A	200
Description	100
Length 2050	50
Length 1250	45
Length 1050	40
	35
	30
	25

Mod. T30.80° also available with H=150

Dimensions in mm

Die V-Opening = 30mm

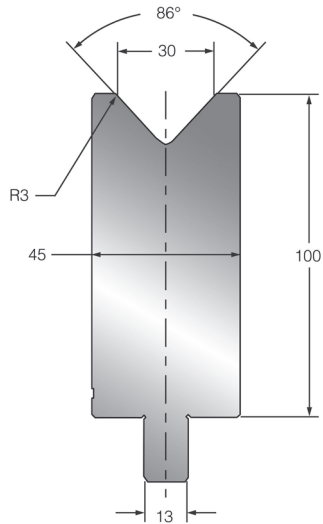

Toolspress Profile	T30.86°
Trumpf Cat. No.	EV027 86°
V-Opening	30
Angle	86°
Height	100
Maximum Loading:	900 kN/m
Weight:	34.7 kg/m

Version B	Sectionalised
Description	Description
Length 4050	Length 250
Length 3050	Length 550
Length 2550	Single
Length 2050	Description
Length 1250	500
Length 1050	300
Version A	200
Description	100
Length 2050	50
Length 1250	45
	40
	35
	30
	25

Dimensions in mm

Die V-Opening = 40mm

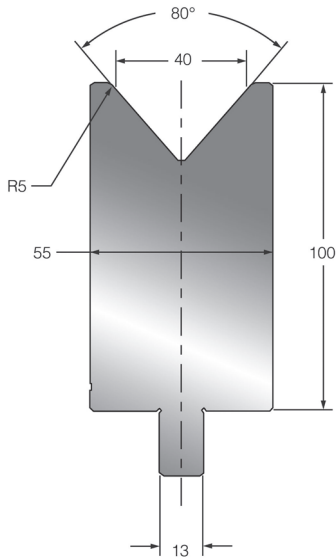

Toolspress Profile	T40.80°
Trumpf Cat. No.	EV W40/80°
V-Opening	40
Angle	80°
Height	100
Maximum Loading:	1200 kN/m
Weight:	40.8 kg/m

Version B	Sectionalised
Description	Description
Length 4050	Length 250
Length 3050	Length 550
Length 2550	Single
Length 2050	Description
Length 1250	500
Length 1050	300
Version A	200
Description	100
Length 2050	50
Length 1250	45
Length 1050	40
	35
	30
	25

Mod. T40.80° also available with H=150

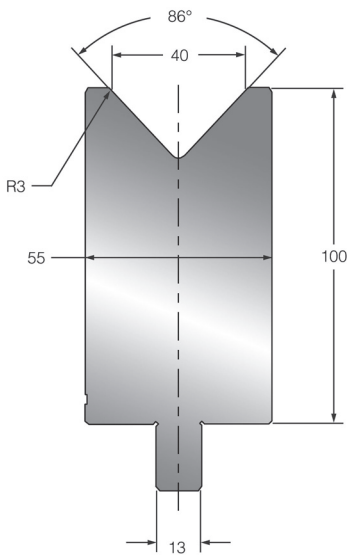

Toolspress Profile	T40.86°
Trumpf Cat. No.	EV028 86°
V-Opening	40
Angle	86°
Height	100
Maximum Loading:	1200 kN/m
Weight:	41.6 kg/m

Version B	Sectionalised
Description	Description
Length 4050	Length 250
Length 3050	Length 550
Length 2550	Single
Length 2050	Description
Length 1250	500
Length 1050	300
Version A	200
Description	100
Length 2050	50
Length 1250	45
	40
	35
	30
	25

Dimensions in mm

Die V-Opening = 50mm

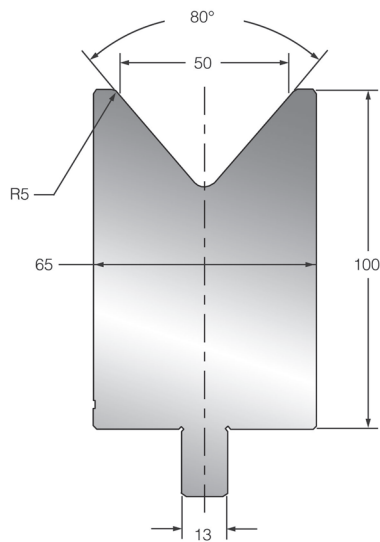

Toolspress Profile	T50.80°
Trumpf Cat. No.	EV W50/80°
V-Opening	50
Angle	80°
Height	100
Maximum Loading:	1500 kN/m
Weight:	46.4 kg/m

Version B	Sectionalised
Description	Description
Length 4050	Length 250
Length 3050	Length 550
Length 2550	Single
Length 2050	Description
Length 1250	500
Length 1050	300
Version A	200
Description	100
Length 2050	50
Length 1250	45
Length 1050	40
	35
	30
	25

Mod. T50.80° also available with H=150

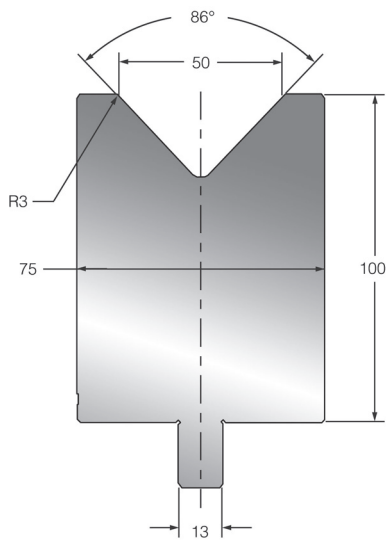

Toolspress Profile	T50.86°
Trumpf Cat. No.	EV029 86°
V-Opening	50
Angle	86°
Height	100
Maximum Loading:	1500 kN/m
Weight:	55.4 kg/m

Version B	Sectionalised
Description	Description
Length 4050	Length 250
Length 3050	Length 550
Length 2550	Single
Length 2050	Description
Length 1250	500
Length 1050	300
Version A	200
Description	100
Length 2050	50
Length 1250	45
	40
	35
	30
	25

Dimensions in mm

Die V-Opening = 60mm - 70mm

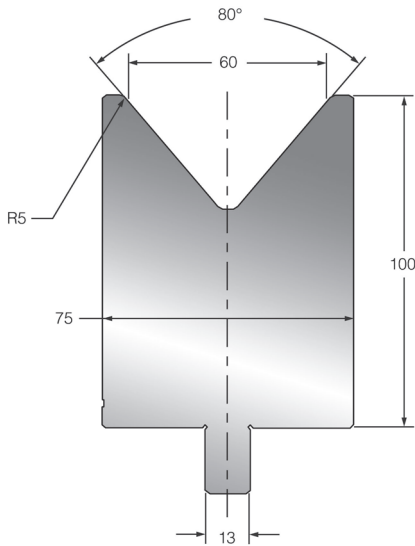

Toolspress Profile	T60.80°
Trumpf Cat. No.	EV W60/80°
V-Opening	60
Angle	80°
Height	100
Maximum Loading:	1500 kN/m
Weight:	51.6 kg/m

Version B	Sectionalised
Description	Description
Length 4050	Length 250
Length 3050	Length 550
Length 2550	Single
Length 2050	Description
Length 1250	300
Length 1050	200
Version A	100
Description	50
Length 2050	45
Length 1250	40
Length 1050	35
	30
	25

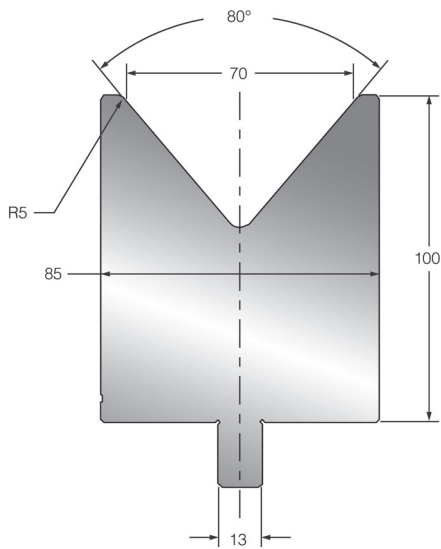

Toolspress Profile	T70.80°
Trumpf Cat. No.	EV W70/80°
V-Opening	70
Angle	80°
Height	100
Maximum Loading:	1500 kN/m
Weight:	56.2 kg/m

Version B	Sectionalised
Description	Description
Length 4050	Length 250
Length 3050	Length 550
Length 2550	Single
Length 2050	Description
Length 1250	300
Length 1050	200
Version A	100
Description	50
Length 2050	45
Length 1250	40
Length 1050	35
	30
	25

Dimensions in mm

Die V-Opening = 80mm - 90mm

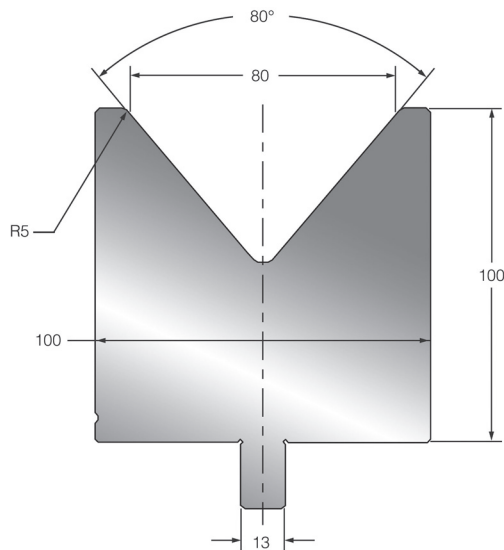

Toolspress Profile	T80.80°
Trumpf Cat. No.	EV W80/80°
V-Opening	80
Angle	80°
Height	100
Maximum Loading:	1500 kN/m
Weight:	64.3 kg/m

Version B	Sectionalised
Description	Description
Length 4050	Length 250
Length 3050	Length 550
Length 2550	Single
Length 2050	Description
Length 1250	300
Length 1050	200
Version A	100
Description	50
Length 2050	45
Length 1250	40
Length 1050	35
	30
	25

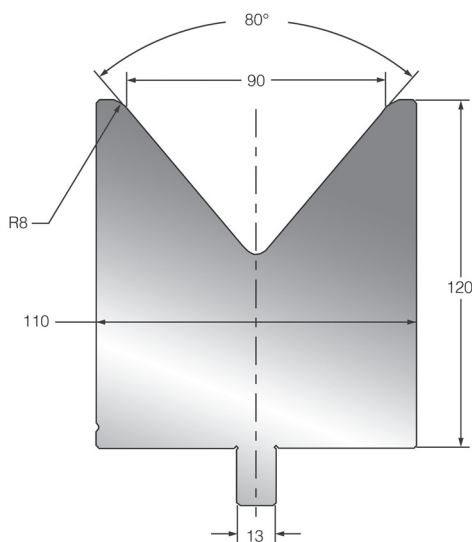

Toolspress Profile	T90.80°
Trumpf Cat. No.	EV W90/80°
V-Opening	90
Angle	80°
Height	120
Maximum Loading:	1500 kN/m
Weight:	84.5 kg/m

Version B	Sectionalised
Description	Description
Length 4050	Length 250
Length 3050	Length 550
Length 2550	Single
Length 2050	Description
Length 1250	200
Length 1050	100
Version A	50
Description	45
Length 2050	40
Length 1250	35
Length 1050	30
	25

Dimensions in mm

Die V-Opening = 100mm

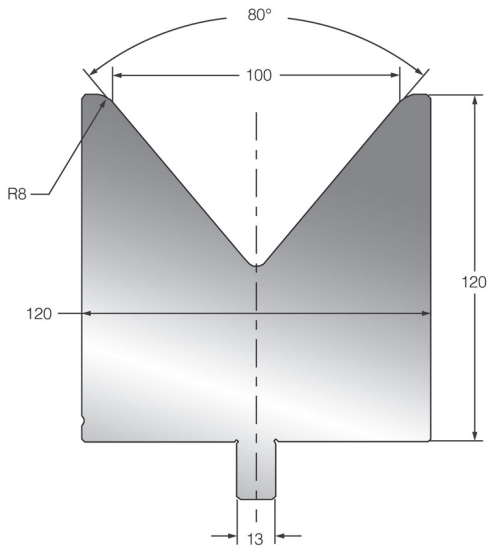

Toolspress Profile	T100.80°
Trumpf Cat. No.	EV W100/80°
V-Opening	100
Angle	80°
Height	120
Maximum Loading:	1500 kN/m
Weight:	89.2 kg/m

Version B	Sectionalised
Description	Description
Length 4050	Length 250
Length 3050	Length 550
Length 2550	Single
Length 2050	Description
Length 1250	200
Length 1050	100
Version A	50
Description	45
Length 2050	40
Length 1250	35
Length 1050	30
	25

Dimensions in mm

Hemming

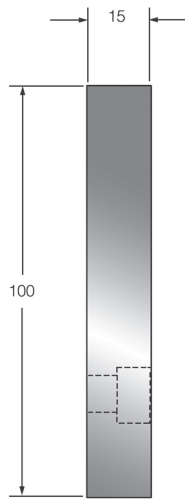

Toolspress Profile	ZDL 100
Trumpf Cat. No.	ZDL
Height	100
Maximum Loading:	1300 kN/m
Weight:	11.6 kg/m

Version B	Sectionalised
Description	Description
Length 4050	Length 250
Length 3050	Length 550
Length 2550	Single
Length 2050	Description
Length 1250	500
Length 1050	300
Version A	200
Description	100
Length 2050	50
Length 1250	45
Length 1050	40
	35
	30
	25

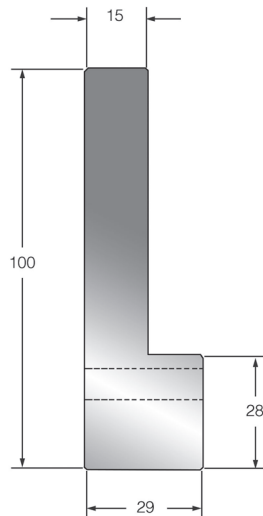

Toolspress Profile	FWZ 100
Trumpf Cat. No.	FWZ
V-Opening	100
Maximum Loading:	1200 kN/m
Weight:	14.8 kg/m

Version B	Sectionalised
Description	Description
Length 4050	Length 250
Length 3050	Length 550
Length 2550	Single
Length 2050	Description
Length 1250	500
Length 1050	300
Version A	200
Description	100
Length 2050	50
Length 1250	45
Length 1050	40
	35
	30
	25

Dimensions in mm

System Division - Dies

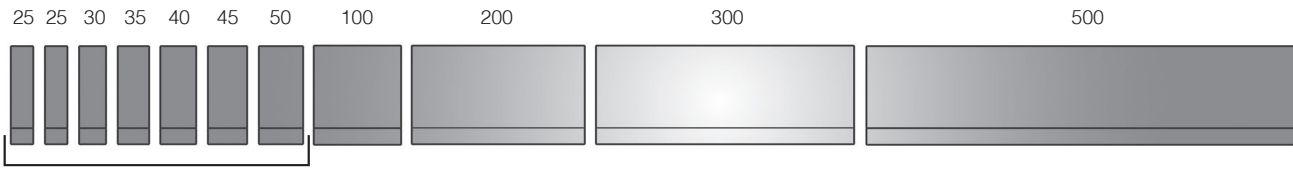

Basic Division 250mm

Division version for tool sets with a weight up to 50 kg/m

System Division Version B

Set	250X	100	200	300	500
550	1	3	0	0	0
1050B	1	3	1	1	0
1250B	1	3	2	1	0
2050B	1	3	1	1	2
2550B	1	3	1	1	3
3050B	1	3	1	1	4
4050B	1	3	1	1	6

Division version for tool sets with weights starting from 50 kg/m

For Dies: T60.80°, T70.80° & T80.80° ONLY

Set	250X	100	200	300
550	1	3	0	0
1050	1	3	1	1
1250B	1	3	2	1
2050B	1	3	3	3
2550B	1	3	4	4
3050B	1	3	5	5
4050B	1	3	7	7

Division version for tool sets with weights of more than 83 kg/m

For Dies: T90.80° & T100.80° ONLY

Set	250X	100	200
550	1	3	0
1050	1	2	3
1250B	1	4	3
2050B	1	6	6
2550B	1	7	8
3050B	1	8	10
4050B	1	10	14

- Benefits:
- High flexibility
 - Short tool set-up time
 - Low purchase cost

- Fewer tool change-overs
- Version most often selected and recommended

25 25 30 35 40 45 50 100

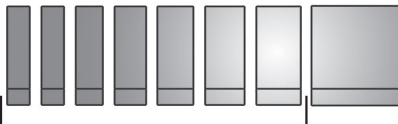

Basic Division 250mm

System Division Version A

Set	250X	100
550	1	3
1050A	1	8
1250A	1	10
2050A	1	18

- Benefits:
- Maximum flexibility
 - Minimum tool set-up time
 - Weight of the individual part pieces very low

System Division Version B/A

The combination of a punch block A-division and a die in B-division will not cause any problems.

Press Force Table

Required Press Force for 90° Air Bends

T = Material Thickness
 F = Press Force (kN/m)
 IR = Inside Radius
 MF = Minimum Flange
 V = Die V Opening

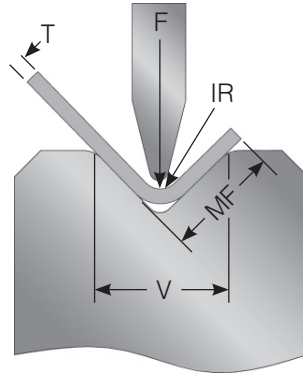

Notes	
* Optimum Die	
• F in kN	
• T, MF, V, IR in mm	

		Material 400 N / mm ² Mild Steel																	
Material Thickness		6	8	10	12	16	20	24	30	40	50	60	70	80	90	100	120	V	
		4.5	6	7.5	9	12	15	18	22.5	30	37.5	45	52.5	60	67.5	75	90	MF	
		1	1.3	1.6	1.9	2.6	3.2	3.8	4.8	6.4	8	9.6	11	13	14	16	19	IR	
Material Thickness	0.75	52*	39	31	26														
	1	93	70*	56	47	35													
	1.25	145	109	87*	73	55	44												
	1.5	209	157	126	105*	79	63												
	1.75		214	171	143*	107	86	71											
	2			223	186	140*	112	93											
	2.5				291	218	175*	145	116										
	3					314	251	209*	168	126									
	3.5					428	342	285	228*	171	137								
	4						447	372	298*	223	179	149							F / m
	4.5						566	471	377	283*	226	189	162						
	5								466	349*	279	233	200	175					
6								670	503	402*	335	287	251	223					
7									684	547*	456*	391	342	304	274				
8										715	596*	511*	447	397	358	298			
10												798*	698*	621	559	466			
12													1005	894*	804*	670			

		Material 700 N / mm ² Stainless Steel																	
Material Thickness		6	8	10	12	16	20	24	30	40	50	60	70	80	90	100	120	V	
		4.5	6	7.5	9	12	15	18	22.5	30	37.5	45	52.5	60	67.5	75	90	MF	
		1	1.3	1.6	1.9	2.6	3.2	3.8	4.8	6.4	8	9.6	11	13	14	16	19	IR	
Material Thickness	0.75	87*	65	52	44														
	1	155	116*	93	78	58													
	1.25	242	182	145*	121	91	73												
	1.5	349	262	209	175*	131	105												
	1.75		356	285	238*	178*	143	119											
	2			372	310	233*	186	155											
	2.5				485	364	291*	242	194										
	3					524	419	349*	279	209									
	3.5						570	475	380*	285	228								
	4							621	497*	372	298	248							
	4.5								628	471*	377	314	269						
	5									582*	466	388	333	291					
6									838	670*	559	479	419						
7										912*	760*	652	570	507					
8										1192	993*	851*	745	662	596				
10												1330*	1164*	1034	931	776			
12													1675	1490*	1340*	1118			

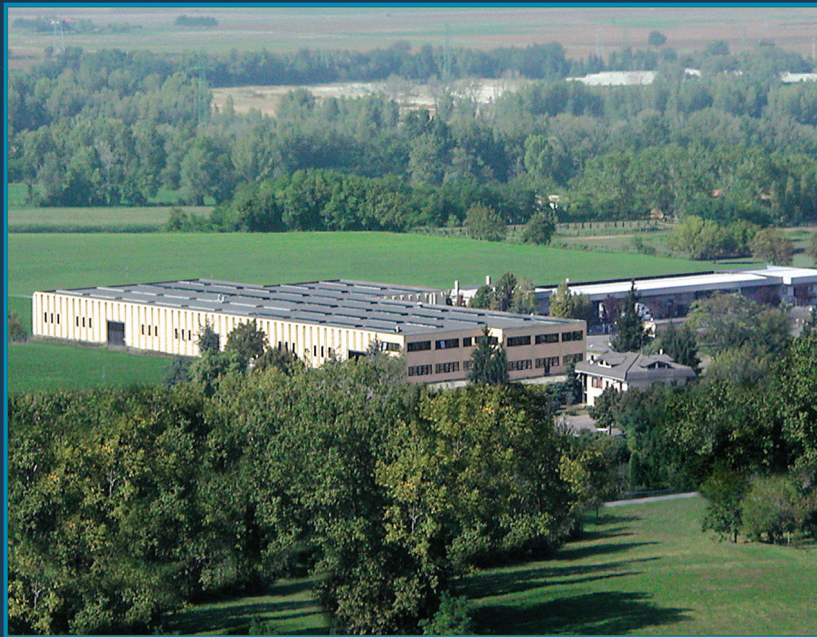

tools  **press**

TP Tooling srl - Via Argini, 17 - S. Maria del Piano - 43037 Lesignano dè Bagni - Parma - ITALY
Tel: +39 0521 850510 - Fax: +39 0521 850796
E-mail: sales@toolspress.com
skype: sales.toolspress

www.toolspress.com